



This is a digital copy of a book that was preserved for generations on library shelves before it was carefully scanned by Google as part of a project to make the world's books discoverable online.

It has survived long enough for the copyright to expire and the book to enter the public domain. A public domain book is one that was never subject to copyright or whose legal copyright term has expired. Whether a book is in the public domain may vary country to country. Public domain books are our gateways to the past, representing a wealth of history, culture and knowledge that's often difficult to discover.

Marks, notations and other marginalia present in the original volume will appear in this file - a reminder of this book's long journey from the publisher to a library and finally to you.

Usage guidelines

Google is proud to partner with libraries to digitize public domain materials and make them widely accessible. Public domain books belong to the public and we are merely their custodians. Nevertheless, this work is expensive, so in order to keep providing this resource, we have taken steps to prevent abuse by commercial parties, including placing technical restrictions on automated querying.

We also ask that you:

- + *Make non-commercial use of the files* We designed Google Book Search for use by individuals, and we request that you use these files for personal, non-commercial purposes.
- + *Refrain from automated querying* Do not send automated queries of any sort to Google's system: If you are conducting research on machine translation, optical character recognition or other areas where access to a large amount of text is helpful, please contact us. We encourage the use of public domain materials for these purposes and may be able to help.
- + *Maintain attribution* The Google "watermark" you see on each file is essential for informing people about this project and helping them find additional materials through Google Book Search. Please do not remove it.
- + *Keep it legal* Whatever your use, remember that you are responsible for ensuring that what you are doing is legal. Do not assume that just because we believe a book is in the public domain for users in the United States, that the work is also in the public domain for users in other countries. Whether a book is still in copyright varies from country to country, and we can't offer guidance on whether any specific use of any specific book is allowed. Please do not assume that a book's appearance in Google Book Search means it can be used in any manner anywhere in the world. Copyright infringement liability can be quite severe.

About Google Book Search

Google's mission is to organize the world's information and to make it universally accessible and useful. Google Book Search helps readers discover the world's books while helping authors and publishers reach new audiences. You can search through the full text of this book on the web at <http://books.google.com/>

PROPERTY OF

*University of
Michigan
Libraries*

1817



ARTES SCIENTIA VERITAS

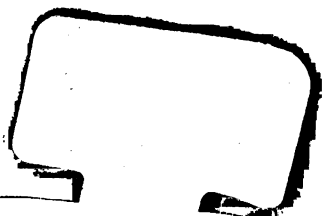

Handwritten text, possibly bleed-through from the reverse side of the page. The text is extremely faint and illegible.





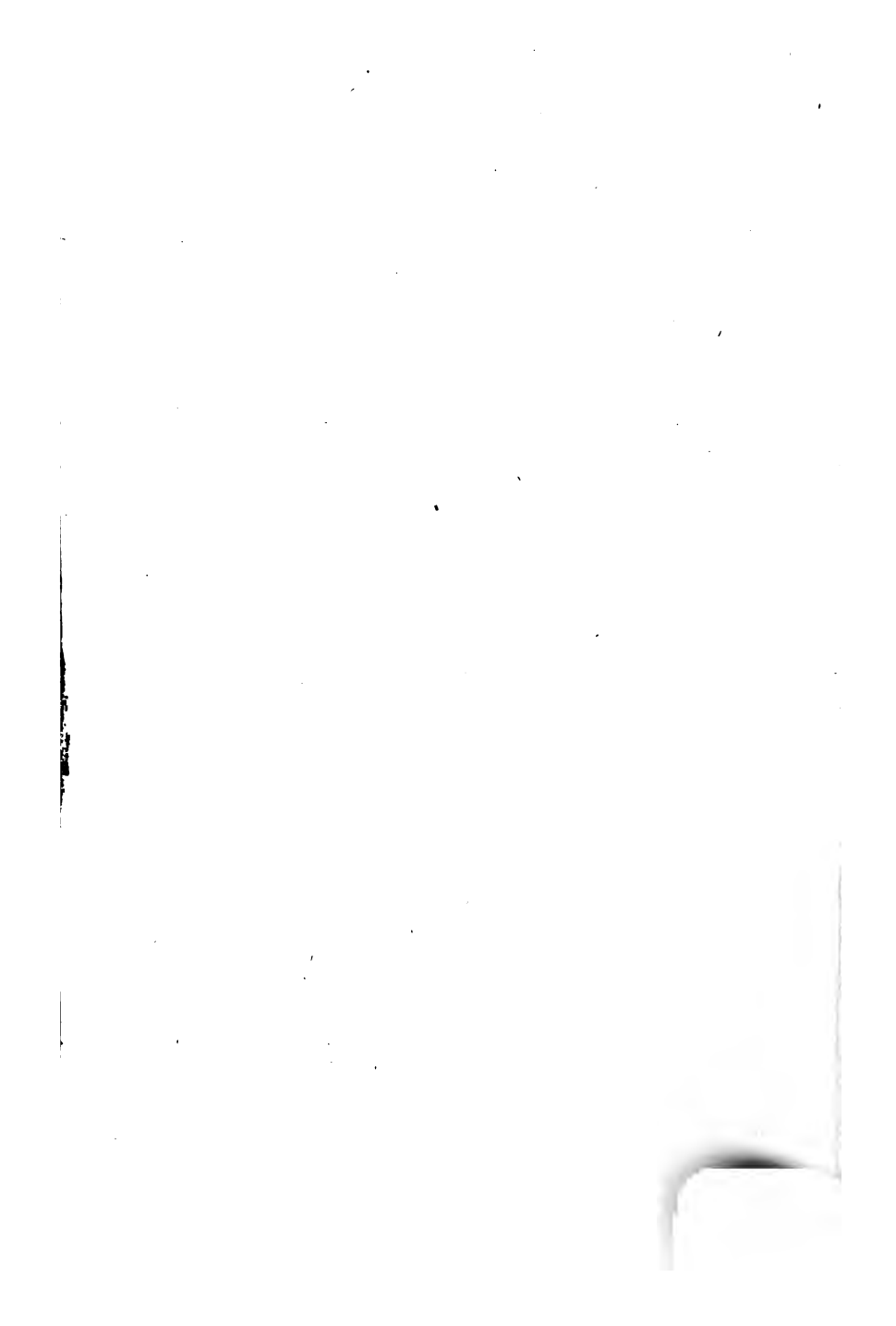

1

2

3

GRAPHIC METHODS
OF
ENGINE DESIGN.

INCLUDING A GRAPHICAL TREATMENT OF THE
BALANCING OF ENGINES.

BY
ARTHUR H. BARKER, B.A., B.Sc.,

SENIOR WHITWORTH SCHOLAR, ETC.,

*Late Assistant to the Professor of Engineering, Yorkshire College, Victoria University;
Author of "Graphical Calculus," etc.*

PRICE THREE SHILLINGS AND SIXPENCE NET.

1897.
THE TECHNICAL PUBLISHING CO. LIMITED,
31, WHITWORTH STREET, MANCHESTER.
JOHN HEYWOOD,
29 AND 30, SHOE LANE, LONDON; AND RIDGEFIELD, MANCHESTER;
And all Booksellers.

ENGIN. LIBRARY

TJ
515
.B26

P R E F A C E .

THE object of the present little work is twofold. Starting with the assumption that the reader knows nothing except what an engine is and the A B C of mathematics and mechanics, it aims primarily at describing and explaining clearly a series of easy constructions for use in the drawing office. Many of these have been devised by the author for practical purposes, and almost all have been used by him in practice, so that he is sure of their utility.

For those young mechanics who wisely or unwisely—usually the latter—aspire to a position in the drawing office, and to junior draughtsmen, it is intended to convey an idea of the sort of mathematical knowledge that is required in designing engines on correct principles.

The second object is to show the intimate relation that must necessarily exist between the science of engineering and the exact principles of what is called “theoretical” mechanics. The book has been written in the firm belief—derived from experience both in teaching and practical work—that the most necessary educational equipment of the engineer is a thorough knowledge of elementary scientific mechanics, for it enables the practical man to keep a clear head in thinking out problems which without it would confuse him hopelessly. If the student possesses this knowledge, he will meet with very little real difficulty in any practical book on any branch of engineering he may take up. If he does not—even if he substitutes for it what is called “applied mechanics,” a term usually given to the description of superficial phenomena which require “theoretical” mechanics for their full explanation—he will find many useful books full of confusing statements which he cannot understand.

But this real knowledge of scientific mechanics is not to be obtained by studying a mathematical treatment of the subject. An engineer's knowledge of mechanics is not the capability of skilfully juggling with x 's and y 's, but a clear conception of a series of experimental facts, the exact relation of which to one another must be perfectly familiar. The mechanism of the steam engine forms a very complete series of illustrations of these principles, and this book is intended to make clear their application to practical work. It contains examples of almost every principle commonly found in books on elementary dynamics. Everything is treated numerically. No principle, however correct, is of any use to an engineer which he cannot translate into figures when necessary. In explaining these applications, the author, while endeavouring to avoid undue prolixity, has not striven after extreme brevity, which latter feature seriously impairs the value to the student of such a large number of excellent books. The beginner cannot see to the inside of brief concise statements. He requires more or less full and informal explanation.

A good deal of attention has been devoted to the subject of balancing. The author does not know of any work which treats this important and somewhat difficult subject in such a way that it can be understood by the elementary students for whom this book is intended. The object has been throughout that nothing should be found here which cannot be understood by anyone who will take the trouble to read it thoughtfully and consecutively.

It has been, in places, somewhat difficult to steer a mean course between pedantic accuracy of expression and a dangerous laxity, such as is too common among engineers. In particular, as regards the words "mass" and "weight," though the author is convinced that it is better in the long run to assign to each its strict meaning, yet, in deference to the objection which so many engineers have to the word "mass," it has not been used more than is absolutely necessary to the sense. No departure has been made from strict accuracy which could cause confusion.

A. H. B.

London,
May 13th, 1897.

CONTENTS.

	PAGE
CHAPTER I.	
Introductory : Size of Engine for given power	1
CHAPTER II.	
Valves Ports and Valve Diagrams	7
CHAPTER III.	
Dimensions of Details	27
CHAPTER IV.	
Compounding.....	47
CHAPTER V.	
Compound Diagrams	67
CHAPTER VI.	
Flywheels	86
CHAPTER VII.	
Theory of Inertia of Moving Parts	97
CHAPTER VIII.	
Inertia Diagrams	106
CHAPTER IX.	
The Motion of the Connecting Rod	121
CHAPTER X.	
Balancing : Force Curves	127
CHAPTER XI.	
Methods of Force Balancing.....	137
CHAPTER XII.	
The Theory of Couples	145
CHAPTER XIII.	
Inertia Couples on an Engine	155
CHAPTER XIV.	
The Balancing of Two-cylinder Engines with Cranks at Right Angles	170
CHAPTER XV.	
General Remarks on Balancing	201

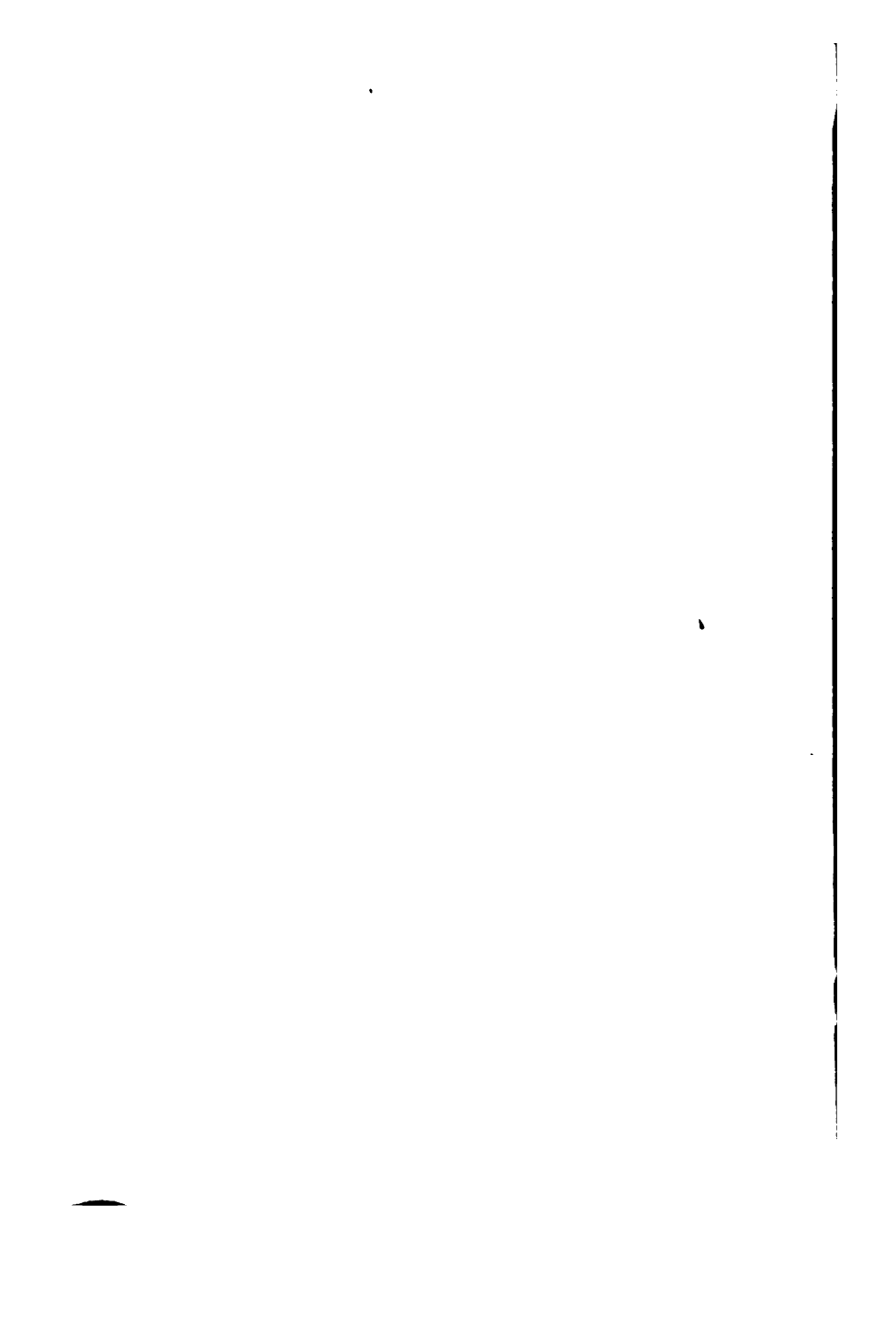

ADDENDUM AND ERRATA.

Page 124, line 9, read : " As described above, the axis of the engine being always kept horizontal. The engine as a whole has, in fact, a motion similar to that of the coupling rod of a locomotive, every line in it keeping always parallel to itself, and each point describing a circle whose radius is always equal and parallel to the crank radius."

Page 37, footnote : For " A and B" read " B and C" throughout.

Page 96, line 26 : For " 273 " read " 546."

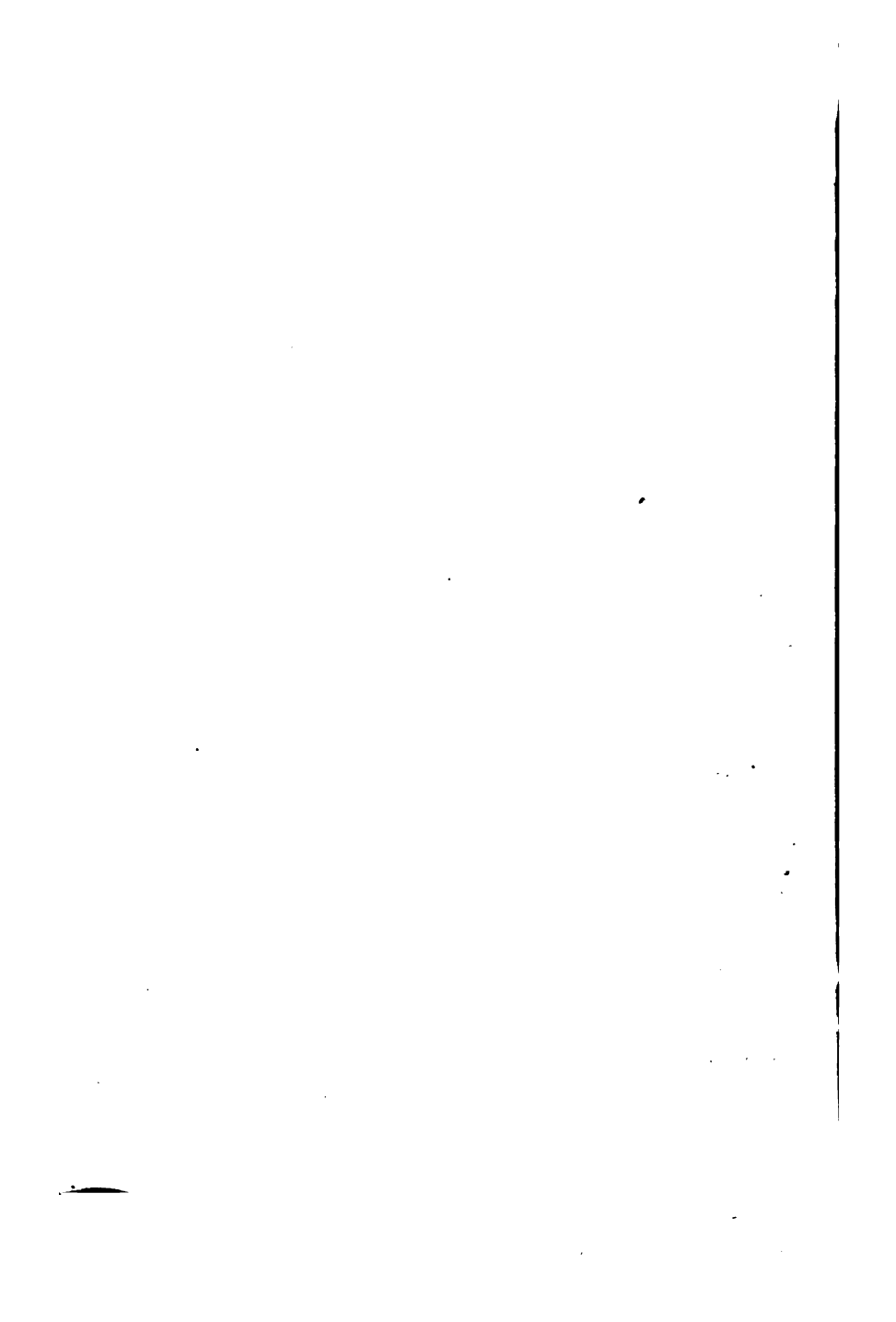

CHAPTER I.

INTRODUCTORY.

SIZE OF ENGINE FOR GIVEN POWER.

IT is proposed in the following chapters to explain the principles of practical engine design by methods as free from mathematical complications as possible. Although there can be no doubt as to the value of a mathematical and scientific training to an engineer, yet the actual amount of knowledge of these subjects which is absolutely necessary even for a first-class designer is really very small. He should, of course, know enough to be able to thoroughly understand the reasons of all the rules he has to use, otherwise he can neither have full confidence nor know exactly when they may be applied. To this end he must be familiar, at least, with algebra as far as simple equations, the First Book of Euclid, enough of the elements of pure and applied mechanics to give him accurate idea of mass, velocity, acceleration, force, and work, composition and resolution of forces, couples, and bending moments, centrifugal force, and similar subjects.

This book also assumes a general acquaintance with the construction of an ordinary steam engine. Of course, it is not to be assumed that merely with such knowledge as this any amount of reading can make a first-class draughtsman. The aim of a draughtsman is to design, as rapidly as possible, a good-looking and convenient machine, which can be cheaply made without any sacrifice of efficiency, and one in which the working parts can

Now, in order to make sure that the engine when made will give at least as much power as is required, the designer must be very careful to allow an ample margin all round for possible deficiencies. Nothing is more unsatisfactory to everybody concerned than to find, after an engine has been built, that it is not quite up to its work, and to be compelled to alter the valves, &c., in order to increase the power. Nothing is gained by trying to cut things too fine.

There are then several things to be assumed from practical experience. These are—

- i. Back pressure, 18 lb. per square inch absolute, suppose.
- ii. Clearance, 10 per cent, suppose.
- iii. Mechanical efficiency, or ratio of brake power to indicated power, 75 per cent, suppose.

It is clear that the work to be indicated per stroke is

$$\frac{12 \times 33000}{150 \times 2} \times \frac{100}{75} = 1760 \text{ foot-pounds.}$$

First draw the required indicator diagram, fig. 1, thus: Take two lines O X, O Y at right angles. Make

$$O A = \frac{A B}{10} = 1 \text{ in.,}$$

suppose, to represent, to some scale unknown, the volume of the clearance in cubic feet. A B then represents the volume swept out by the piston every stroke. Take A C to scale representing the absolute initial pressure in the cylinder per square foot. This should be about 8 per cent below the boiler pressure, to allow for wire-drawing, &c. The initial pressure is therefore about $75 \times 144 = 10,800$ lb. per square foot. The scale may be 1 in. = 10 lb. per square inch = 1,440 lb. per square foot. Take A D = the back pressure = 18 lb. per square inch = 2,600 lb. per square foot. Draw C F = admission volume of stroke = $\frac{1}{2}$ A B, and through F draw the hyperbola F G, with asymptotes O Y, O X, by the construction shown in the figure. This represents the

pressure of the steam at any point during the expansion. Thus, when the volume of the steam (including clearance) is OL , the pressure will be LK .

Now, it is clear that number of foot-pounds done in one stroke by steam under pressure = total mean pressure on piston in pounds \times length of stroke in feet = mean pressure per square foot \times number of square feet in piston area \times length of stroke in feet = mean pressure per square foot \times volume of steam in cubic feet, which is therefore represented by the area of the figure $CDEGF$ to some scale which we shall have to find (since any rectangular area = length \times breadth). Suppose this area is found to be 46.9 square inches, as measured by planimeter or otherwise. This area we know represents 1,760 foot-pounds. Hence area scale is 1 square inch

$$= \frac{1760}{46.9} = 37.6 \text{ foot-pounds.}$$

If, then, the diagram were a square of 1 in. side, its area would represent 37.6 foot-pounds.

Now, since 1 in. vertical represents

$$1440 \left(\frac{\text{lbs.}}{\text{ft.}^2} \right),$$

let 1 in. horizontal represent x cubic feet; we have then

$$1440 \left(\frac{\text{lbs.}}{\text{ft.}^2} \right) \times x (\text{ft.}^3) = 37.6 \text{ foot-pounds.}$$

$$\text{Hence} \quad x = \frac{37.6}{1440} = .0262.$$

Hence 1 in. horizontal represents .0262 ft.³, whence whole volume of stroke = 10 in. = .262 cubic feet.

This can be easily calculated without drawing a diagram, if we remember that the area of the hyperbola, $pv = \text{constant}$ between any two volumes v_1 and v_2 , is

$$pv \log_e \frac{v_2}{v_1}$$

where $p v$ are any *simultaneous* values during the expansion of the absolute pressure and volume. Thus, in the present case, the area of the figure F H B G is

$$HF \times OH \times \log_e \frac{OB}{OH}$$

Now let v be the total volume of the stroke of the piston in cubic feet—*i.e.*, area in square feet \times stroke in feet = A B. We have then—

$$OA = \frac{v}{10}$$

$$AH = \frac{v}{2}$$

$$OH = \frac{v}{2} + \frac{v}{10} = \frac{3v}{5}$$

$$OB = v + \frac{v}{10} = \frac{11v}{10}$$

Also area D A B E = A D \times A B = in this case $2,600 \frac{\text{lb.}}{\text{ft.}^2} \times v$, since the back pressure is 2,600 lb. per square foot.

This is the work lost by back pressure every stroke. Now we have area

$$CDEGF = CAHF + FHBG - DABE$$

$$= \frac{pv}{2} + \frac{3pv}{5} \log_e \frac{v_2}{v_1} - p^{(b)} v.$$

Now we have given that—

$p = 75$ lb. per square inch absolute = $10800 \frac{\text{lbs.}}{\text{ft.}^2}$ (absolute pressures must always be used).

$$p^{(b)} = 18 \text{ lb. per square inch} = 2600 \frac{\text{lbs.}}{\text{ft.}^2}$$

Hence area

$$CDEGF = 5400v + 10800 \times \frac{3v}{5} \times \log \frac{11v}{3v} - 2600v$$

$$= v(5400 + 6480 \log \frac{11}{3} - 2600)$$

$$= v(2800 + 6480 \times 0.61)$$

$$= 6750v,$$

which, as before, we know

$$= 1760 \text{ foot-pounds,}$$

whence $v = \frac{1760}{6750} = 0.262 \text{ cubic feet,}$

$$= 452 \text{ cubic inches.}$$

This volume we can divide as we please between the piston area and the stroke, bearing in mind that the mean speed of the piston should be not greater than 10 ft. per second, unless in exceptional circumstances. That is to say, we can fix on—

(i.) Any stroke we please, say 8 in., and find the corresponding value of the area of the piston, which will in this case be

$$\frac{452}{8} = 56.5.$$

Then, if d be the diameter of the cylinder, we have—

$$\frac{\pi}{4} d^2 = 56.5$$

$$d = \sqrt{\frac{56.5 \times 4}{\pi}}$$

$$= 8.5 \text{ in.}$$

(ii.) Or we can determine arbitrarily the diameter of the cylinder, say 10 in., and find what length of stroke will give the required volume. Thus, area of a 10 in. circle = 78.5. Then stroke

$$= \frac{452}{78.5} = 5.75 \text{ in.}$$

The mean piston velocity in feet per minute will clearly be in this case $150 \times 2 \times \text{stroke in feet}$. This should not be greater than 600.

CHAPTER II.

VALVES, PORTS, AND VALVE DIAGRAMS.

THE area of the ports can be now determined so that the steam velocity through them is (if possible) not greater than 80 ft. per second. In large quick-running engines using high pressures this velocity is often greatly exceeded, owing to the necessity of keeping down the size of the ports. Excessive wire-drawing (or fall of pressure in the cylinder below boiler pressure) is always the result of a high steam velocity through the ports.

We have—

Steam volume per second = port area \times 80 ft. per second =
volume of cylinder \times strokes per second.

Hence in this case—

$$\text{port area} = \frac{.262 \times \frac{500}{60}}{80} = .0164 \text{ square feet.}$$

This area must therefore be the product of length and width of port.

In designing the valve and valve face, we have to work, as is usual in machine design, by the method of "trial and error"—that is to say, suppose we have to determine, as here, values for three or four variables which depend on one another, we have to fix arbitrarily one or two of them, and determine the others to suit. If it is found subsequently that for some reason these will not answer the purpose, we have to correct the design accordingly. Now, in this case we only know that—

1. Length of port \times width = .0164 square feet,
= 2.36 square inches.
2. Cut-off takes place at half stroke.
3. Compression takes place at three-quarter stroke.
4. Ports are to be fully opened to steam and exhaust.

We have to design a valve to fulfil all these conditions. First, we fix arbitrarily length of port opening $3\frac{1}{2}$ in., suppose; this gives a width of port of $\frac{3}{8}$ in. The ratio $\frac{\text{length}}{\text{width}}$ is usually from 6 to 10. The width of the exhaust port must be such that when the valve is at the end of its travel the exhaust port is open by at least the width of the steam port. A width of 2 or 2.5 times the steam port is usually enough to secure this. Hence we provisionally fix the exhaust port width at $1\frac{1}{8}$ in. Any of these dimensions may have to be altered if we afterwards find them unsuitable. The width of the bar between the steam and exhaust ports must be great enough to enable it to withstand the steam pressure on it. The thickness of the metal is usually about the same as the thickness of the cylinder metal. The width of the actual working surface of the bar is usually about three-quarters of the width of steam port. Assume in this case width of bar = $\frac{1}{2}$ in. The only remaining point about the cylinder face is that the edge must be in such a position that when the valve is in its extreme position its edge just overshoots the edge of the cylinder face on each side. Thus the cylinder face is completely determined. The lap of the valve will probably be about $\frac{3}{8}$ in. The minimum half throw of the valve is then lap + width of port, and the maximum = lap + width of port + width of bar; but it is usual to keep it very near the former, so we select $1\frac{1}{8}$ in., say, for the provisional half throw of the valve. We have then to consider how to make the valve so that it may (1) cut off at half stroke, and (2) close the exhaust port at, say, $\frac{3}{4}$ stroke. For problems such as this the Zeuner valve diagram is often used. This, however, is not an accurate construction, however pretty it may be considered as a piece of geometry. To those who are well acquainted with harmonic motion it is easy to see that Zeuner's valve diagram is merely an ingenious method of setting out a radial curve of displacements in S.H.M. The construction for Meyer's gear is an application of the

principle that two S H M's of equal period in the same direction when superposed produce a relative S H M. But engineers are not always as familiar with S H M's and relative motions as they might be, and it follows that they use this construction as a rule of thumb—sometimes with not very happy results, as the valves of many engines show. We shall not explain it here, as it is too mathematical in character. If it be already known, it is very useful as a first approximation to give the approximate angle of advance and lap of valve we require. It may be found in any book on the steam engine. These values will have to

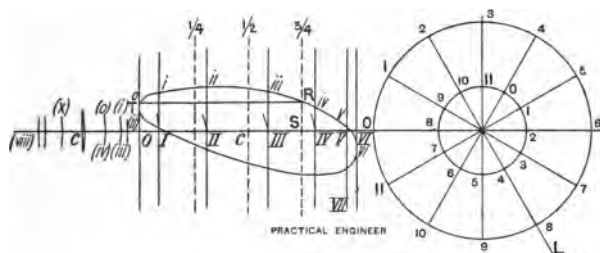

FIG. 2.

be further corrected by trying over the valves found by means of the diagram which will now be explained.

We shall first explain the construction for a single valve, and afterwards the construction for two valves. Draw the line of centres, fig. 2, a circle representing to as large a scale as possible the path of the crank pin, and another representing to the same scale the path of the centre of the eccentric sheave. In some cases where the stroke of the piston is comparatively large and the stroke of the valve small, it may be desirable to draw the latter circle to a larger scale than the former. In this case everything connected with the valve, such as the eccentric rod, must be drawn to the valve scale, and all the measurements except those of piston position must be measured by this scale. This should not be used until the method is thoroughly understood, as it

is apt to cause confusion. A construction will be presently explained, whereby these valve ellipses, even for very large engines, may be drawn full size on an ordinary sheet of paper.

Divide the crank circle into a large number—say 32—of equal parts, starting from dead centres. Number them 0 to 31 (only a few points are shown in fig. 2, to avoid confusion). Set out the assumed angle of advance ($11 A$) where A is the centre of the shaft; 0 will then be the position of the centre of the eccentric when the crank pin is at 0. Divide the eccentric circle into the same number of parts as the crank circle, starting at 0, and number them corresponding to the numbers on the crank circle. Thus the eccentric centre is at 3 when the crank is at 3, and so on. (This separate division of the circles may be avoided by setting off the angle of advance at $9 CL$, and marking valve positions on AL produced.) Set a pair of trammels (or mark a piece of paper) to the scale length of the connecting rod, and placing the point on each of the crank points 0, 1, 2, 3 in turn, mark off on the line of centres the corresponding position of the crosshead pin at $O, I, II, III, \&c.$, and erect ordinates at these points. Mark off at C the central position of the piston. It is thus clear that when the crank is at 4, for instance, the piston is at a distance $C-IV$ from the centre of its stroke. Now set the trammels to the scale length of the eccentric rod, and proceed on the eccentric circle as before, marking and numbering the positions of the eccentric rod pin on the line of centres. Mark c as before, for the central position of the valve. Now mark off, with dividers, at $O (o)$, the distance by which the valve is *in front of* its central position when the crank pin is at near dead centre—i.e., $c (o)$. Similarly, make $I. (i.) = c (i.)$, $II. (ii.) = c (ii.)$, and so on for all the other points, measuring *below* the line of centres for distances to the *left of* c . Draw a curve accurately through these points so obtained. This curve shows accurately at a glance, and independently of mathematics,

the varying position of the valve corresponding to all positions of the piston—*e.g.*, when the piston is at V., the valve is at a distance V. (v.) from the centre of its travel.

We can now easily determine the lap of the valve to cut-off at any point of the stroke and the corresponding lead. Imagine the valve in its central position, as in fig. 3. It is

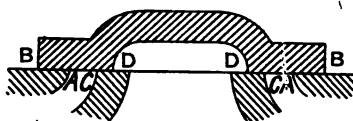

FIG. 3.

clear that the length A B is the lap, so that when the valve is moved a distance A B in either direction, one or the other port will be just closed, and no more. Cut-off, then, will take place when the valve is at a distance = A B from its central position. Conversely, if we desire cut-off to take place when the piston is at, say, $\frac{2}{3}$ stroke, we must make the lap equal to the distance which the valve is from its central position at that time—that is to say, the lap is S R, fig. 2,

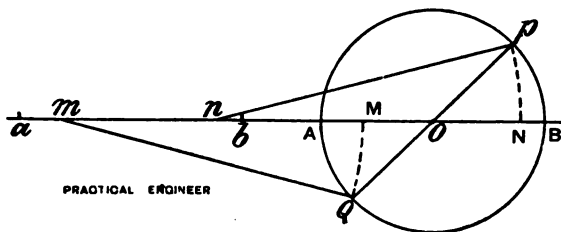

FIG. 4.

and the amount of opening of the port is at any point the vertical distance of the line T R from the curve. The lead is then T (o). Precisely the same construction holds for the other side of the piston, and also for inside lap for any desired compression. The lap will be different on the two sides of the valve. The reason of this is that, owing to the

effect of obliquity of the connecting rod, the crank has not turned so far during the forward stroke when the piston has described three-quarters of its travel as it has for the same fraction of the travel on its return stroke. Thus, when the crank pin is at P, fig. 4, the piston is at a distance A N from the left end of its stroke; while for a diametrically opposite position Q, B M represents the distance travelled by the piston from the right end; and B M is clearly less than A N. The obliquity of the valve rod is much less than that of the piston rod. The position of the valve, therefore, is not affected so much by obliquity as that of the piston. This is briefly the cause of the difference. Care must be taken with the inside lap C D, fig. 3. If the valve is moved to the *left* by a distance C D, the left port will be just closed to exhaust; therefore, make the inside lap on the left = the distance (positive or negative) by which the valve is on the left of its central position when the piston is at the point where compression is to commence, and make the inside lap on the right = the distance by which the valve is on the right of its central position when compression on the right-hand side is to commence.

The method of drawing the diagram full size is as follows: Draw two concentric circles, as before, to represent the paths of the centre of the crank pin and the centre of the eccentric sheave full size, and mark them out as before into numbered corresponding positions of these centres.

Suppose Q, in fig. 4 (a), is the position of the eccentric sheave centre, corresponding to position P of the crank pin. Now, if we describe two circular arcs P M, Q N, with centres which are the corresponding positions of the crosshead pin and eccentric pin respectively, cutting the line of centres in M and N, it is clear that the position of M between A and B is the same as the position of the piston in its stroke, while the position of N between C and D is that of the valve. If, then, we can draw these arcs without having resource to the centres *p* and *q*, it is clear that we can find the displacements of piston and valve, or at least

the latter, full size on an ordinary sheet of paper. These arcs may be drawn by means of templates of cardboard shaped as shown shaded in the figure, and used on a T square as an ordinary set-square is used. A central horizontal line must be drawn on each, which must be placed in position on the line of centres. The line AB (which may be on a smaller scale than CD if the template is also cut to a proportionately smaller radius) must be used as the base on which valve positions are to be plotted.

For Meyer's valve gear the construction is precisely the same as for a single valve. But we now get two elliptic figures as curves of valve position, one for each eccentric, and it is by the intersection of these that we determine the time of cut-off, &c. The most common practice in engines with valves of this type is to put the expansion eccentric exactly opposite the crank. (It is placed forward of this

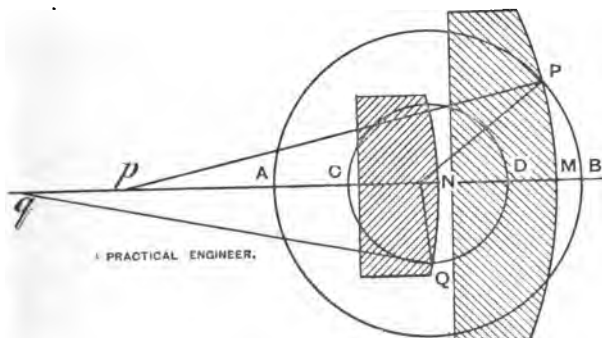

FIG. 4A.

position if a very early cut-off is desired, and behind it for a late one.) In this case the curve of position of the expansion merges into one line, as will be found by trial. The reason for this can be easily seen by anyone who thoughtfully examines the method of drawing the curve. As all problems of relative motion are somewhat confusing, some care will be necessary.

At fig. 5 will be seen a pair of curves which have been obtained in the way explained above. Let us examine carefully the meaning of each one. Curve AB shows the distance of the main valve from its central position corresponding to every point in the stroke. Let the reader dismiss from his mind every other part of the valve except the cutting-off edge R on one side, say the left-hand side.

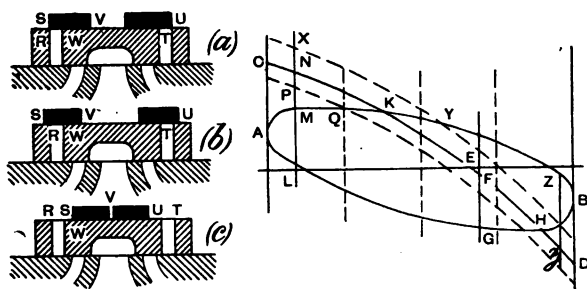

FIG. 5.

Now, curve AB represents the distance which the left-hand cutting-off edge of the valve is from *its own* central position at any point of the stroke.

Now consider the curve CD. This represents the distance which the cutting-off edge S of the expansion valve is from *its own central position* at any point of the stroke. Now, it is clear that at the point K, where the two curves intersect, each valve has been moved *the same distance* to the right, and therefore the cutting-off edges are exactly as far apart as they are when both valves are placed centrally, as in (a) (b), (c), fig. 5.

(a) If, for instance, the distance SU is = RT, as in (a), then at a point of the stroke corresponding to K cut-off will take place, because the cutting-off edges are then together, for it is clear that moving both valves the same distance in either direction will not alter their relative positions. It is thus clear that in case (a) the vertical distance between

curve A B and C D represents the *distance apart of the cutting-off edges* S and R at any point of the stroke, S being to the right of R when curve C D is *above* curve A B, and on the left when C D is below A B. Thus, on the return stroke, when, say, a quarter stroke has been described, the piston is at E and moving towards the left. Here F in curve C D is above G on curve A B, and hence S is on the right of R by a distance F G, and so on.

Now dismiss S and R from the mind completely, and consider solely edges T and U in case (a). It is clear that they will come into operation on the return stroke only, and, since the valves are together at H, it is at this point on the return stroke that cut-off takes place. Precisely similar reasoning holds for T and U as is given above for R and S—that is, the vertical distance between the two curves gives the distance apart of edges T and U, U being on the left of T when C D is below A B, and *vice versa*.

(b) Now let us turn to case (b)—*i.e.*, when $S U > R T$, or when the expansion valve in its central position overlaps the main valve ports. Cut-off will now take place on the left-hand side, when the expansion valve is moved toward the right of the main valve by a distance S R—that is to say, when the difference between the displacements of the main valve and of the expansion valve is = S R. The distance apart of S and R will be the same as in case (a), except that in effect a piece R S has been tacked on the valve arranged as at (a), which, of course, diminishes the distance apart of the edges when S is on the right of R, and increases it when S is on the left of R.

Now, we have seen that in case (a) M N gives the distance apart of the edges when the piston is at L; hence, if we make $N P = R S$ (b), we see that the distance between the edges is given at M P. Similarly, if we draw a curve (dotted) which at all its points is a distance R S (b) vertically below curve C D, then the vertical distance between this dotted curve and curve A B will, as before, give the distance apart of the cutting-off edges with the same distinction

between left and right as given above. Hence we see that cut-off must take place at Q instead of, as before, at K .

(c) Now consider case (c). It is evident that when cut-off takes place on the left-hand side, in this case the expansion valve must, *relatively to the main valve*, be moved towards the *left* by a distance SR , and that the distance between the cutting-off edge will be the same as in case (a) + distance RS when the edge of the expansion valve is on the right, and $-RS$ when it is on the left. Hence, exactly as before, if we draw in a curve XY , which at all its points is vertically *above* the curve CD by a distance RS (c), then the vertical distance between this curve and AB at any point of the stroke gives the distance between the cutting-off edges; thus, when the piston is at L , the distance apart of the cutting-off edges is MX . This makes it very clear how increasing the distance between S and U of the expansion valve alters the cut-off. Just as in the case of a single valve, we may call the distance RS the "lap" of the expansion valve. In case (c) the lap is negative, and we may very easily determine the lap required for any given cut-off by measuring the distance by which the expansion valve curve is at that point above the main valve curve. That this lap ought to be very different on the two sides of the valve is obvious from the diagram. The determination of the lap on the right-hand side is exactly the same as on the left. If any difficulty be experienced in determining whether the lap on the right side is positive or negative, just turn the diagram upside down, and it will be exactly similar to the other side. Another point which this diagram enables us to check with great ease is that the inside edges of the expansion valve, such as V , be not allowed to overshoot the edges, such as W of the main valve port. In that case steam would be re-admitted over the back of the valve, and the indicator card would then have the shape of fig. 6, which is very bad indeed, because it not only destroys all the economy of expansive working, but throws away a very large part of the work which might be got from non-expansive working.

It is clear that, in order to prevent this, the distance between W and V, when the valves are both in their central positions, must be greater than the greatest possible distance apart of the centres of the two valves; or, in other words, the width S V of the expansion valve must be greater than (the greatest distance by which S ever overlaps R + width of port)—i.e., $S V > S R_{(max)} + R W$.

This distance between S and R is greatest at the point where the curves A B and C D are parallel, as they are (for the left-hand ports) at Z z, and (for the right-hand ports) at L P.

If the expansion is to be variable, the greatest danger of re-admission occurs when the expansion valve is set for earliest cut-off. If this point be tried over in the way

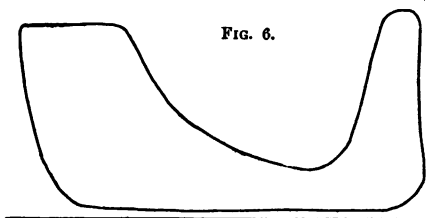

here explained, and found right for the earliest cut-off possible, the valve will be quite safe for all other points. Engines should be so designed that it is mechanically *impossible* for this re-admission to occur. It should never be left to the discretion of the engine attendant not to over wind the expansion wheel, but it should be put out of his power. It is safe to assume, that if there is any possible way for the engine attendant to work an engine wrongly, he will discover that method and use it as much as possible.

NOTE.—In the case of a variable cut-off the expansion eccentric should be so set that it is *vertical* at that point of the stroke where cut-off is usually to take place. This gives the most rapid cut-off possible at that point. The larger the stroke of the expansion eccentric the more rapid the cut-off.

STEPHENSON'S LINK MOTION.

A modification of the same method is very useful in designing valve gears of other types, of which a very large number have been invented. When once the method has been understood, the application to any gear whatever is quite easy. In illustration we shall apply the method to Stephenson's link motion and Joy's valve gear.

The first of these consists of two eccentrics whose centres are A and B, fig. 7, and two eccentric rods A C and B D con-

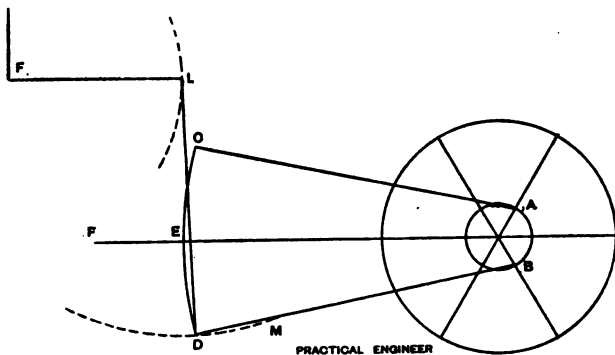

Fig. 7.

ected by a link, whose centre line is CD, in which slides a block at E, which is connected with the valve rod EF. One of the eccentrics is set so as to drive the engine in one direction and the other in the other, as shown. The valve can be put under control of either of the eccentrics by means of a lever which actuates the bell crank F, and so raises or lowers the pair of rods AC, BD, that either one or the other has most influence in actuating the valve. The most common method of suspension is that indicated in fig. 7, where the swinging rod LD is attached to D. If other methods of suspension are used, the diagram must be modified accordingly, as will be presently explained. Consider one

position of the point L, as shown. It is clear that for this position of L the point D describes a circle DM, with L as centre. Mark the crank circle out as in fig. 2, also the eccentric circle or circles, numbering them in the same way as before, so that 1 on one circle corresponds to 1 on the others, and so on. Obtain a set of ordinates corresponding to the positions 0, I., II., III., &c., of the crosshead pin, as before. Now set the trammels to the scale length of the eccentric rod BD, and mark off on the circle DM, the positions of the pin D corresponding to the various positions of the crank pin. Find and number the corresponding positions of the point C by the intersections of two circles, one with D as centre, and the length of the link centre to centre DC, as radius, and the other with A as centre and AC the length of the eccentric rod as radius. Now make a template of cardboard representing the centre line of the link CD to scale. The shape of this link will be presently discussed. Assume for the present that it is a circular arc of given radius; place this template so that its edge passes through C and D in each of their corresponding positions, and mark off and number on the line of centres at E the point where the template in each of these positions cuts the line of centres. The motion of this point gives the exact motion of the valve, which can be plotted as before on a base representing the position of the piston, and a curve of valve position drawn through the points. This curve is, of course, treated in exactly the same way as the curve in fig. 2. Several of these curves have been obtained in fig. 8, to show the effect of gradually raising the link. It will be seen that when the glut or die sliding in the link is opposite the end of the eccentric rod the valve curve is practically the same as in the case of a single eccentric. Raising the link causes the valve ellipse to become narrower—in other words, causes the throw of the valve to diminish, thereby both diminishing the lead and causing the valve to cut off earlier, as is seen in fig. 8, where cut-off, in curve 1 occurs at L, whereas in curve 2 it occurs at M, &c.

On continuing to raise the link, it will be seen that the ellipse merges into a line, as is almost the case in curve 3. When this is the case, it is clear that if the laps of the valve

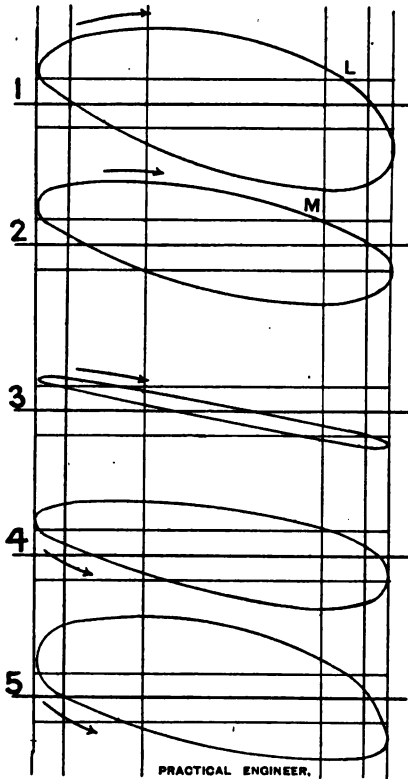

FIG. 8.

be small enough the engine will run at very small power in either direction indifferently. If, however, the laps be too great for this to happen, then steam and exhaust will both

be entirely cut off from both sides of the piston. The minimum value for the laps, in order that this may be the case, will be the maximum height of the curve, for it is clear that the lap lines must both be entirely above or below the curve. On continuing to raise the link, the ellipse again opens out, but is described in the *reverse direction*, as shown by the arrows. This shows that if the engine were to start running in the same direction as before (as it will do, owing to the lead, if the crank is *slightly* above dead centre), the motion of the valve will immediately cause this direction to be reversed by admitting steam to meet the advancing piston, and exhausting the steam which is driving the piston. In fact, the engine must go round in the same direction as the ellipse is described, when the points on the circle are taken in clockwise order.

The objects to be aimed at in design are: (1) To secure that, wherever the link may be, the valves move equally on each side of the ports.* Of course, in order that the die may fit the link at all points without any "slack," it is necessary that the form of both cheeks of the slot must be portions of concentric cylindrical surfaces, and the die must be fitted to the same radius. It remains to determine the radius which will secure that the valve is kept central. This is found to be nearly the length, centre to centre, of the valve rod, or more nearly the distance from the pin where the centre lines of the eccentric rods cut one another, when the crank is on the dead centres. The best length is somewhere between the two, which can only be found by trial. When the engine has to run equally in both directions, the two eccentrics must be placed symmetrically, or nearly so; but when almost all the running is to take place in one direction, it is sometimes thought desirable to keep the lead constant for this direction, while the lead for the other direction varies a good deal. This may be secured by slightly shifting one eccentric forward.

* In some cases it is found in practice that an engine runs better if this condition is not exactly fulfilled—*e.g.*, in vertical engines and locomotives.

(2) The next point to be considered is that the slip of the die in the link must be diminished as far as possible. If the die slips about much in the link, a great increase of friction and wear of the die and link is the result. Designers differ as to the best way of avoiding slip. Some maintain that the link should be suspended from its centre while the suspending rod is as long as possible; others maintain that it should be suspended as in fig. 7, by which means a longer suspending link is obtained. This is the usual practice in locomotive design, where the proximity of the boiler prevents the use of a very long link. In some cases the curvature of the path of the point D, fig. 7, may be utilised to diminish slip. This can often be effected for one position of the link at the expense of greater slip for other positions. In any case the slip curve should always be obtained for several positions of the link in the following way. Cut a piece of millboard (fig. 10, shaded edge) to a radius equal to that of the centre line of the link to scale, marking the position of the centres of the pins R_1 , R_2 , and place this on the diagram in all the positions which the link assumes in one revolution, as in the construction explained at fig. 7, where CD would represent the position of the shaded circular edge of the millboard at dead centres. Mark off and number at E on the millboard template the point where the line of centres cuts the edge of the template. Do this for all the positions of the eccentrics in one revolution, and the amount of slip on the die from its central position will be seen by bisecting the distance between the extreme marks on the template. These distances can be plotted on a base of piston positions if desired, and the ingenuity of the designer must be brought into play to reduce the slip as much as possible at those parts of the link which have to be most used.

A method of designing link motions so as to secure a minimum of slip for one position of the block in the link is as follows: Make a template, fig. 10, to represent the centre line of the proposed link to scale. Mark on this template

points R_1, R_2 , representing the centre of the pins by which the rods are attached to the link ; also mark on the edge representing the centre line of the link the desired position P of the die in the link ; also mark on the template several points $Q, Q, \&c.$, from among which the position of the suspending link pin is to be selected. Next place the

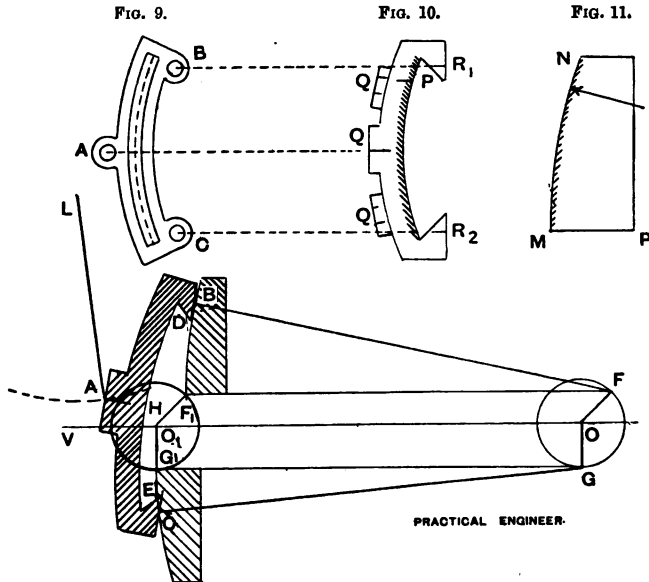

FIG. 12.

template on the drawing in such a position that the point P is on the line of centres, and the points R_1, R_2 are on their respective circles struck with radius equal to the length of the eccentric rods, and from centres which are the corresponding positions 11, 22, &c., of the eccentrics. When the template is in position mark on the paper the positions assumed by all the points Q , and label them so that they may be recognised. Do this for all successive

positions of the eccentrics, and then draw curves representing the paths of the points Q. That position of Q should be selected for the position of the suspending pin which most nearly describes an arc of a circle, and the centre of this arc should be the suspending point.

If the eccentric rods are "crossed"—i.e., if the eccentric A, fig. 7, is made to drive D, and B to drive C—the effect is to increase the lead as the link is raised. The diagram is drawn exactly as before.

As many engines are made with the link suspended from the middle, it may be desirable to explain a convenient method of working out the diagram in this case, as it is more difficult than in the case explained above.

The shape of the link is usually as shown at fig. 9, A being the hole for the pin by which it is attached to the swinging link, and B and C the points of attachment to the ends of the eccentric rods.

It is very desirable (as already pointed out) to increase the scale of the drawing as far as practicable for the sake of accuracy, and a method of drawing this diagram full size without any undue expanse of paper being required is very useful. It is clear that if we can dispense with the centres of the crank shaft and actual eccentrics, there will be no difficulty in drawing any ordinary gear full size on an ordinary sheet of paper.

Let it be required to find the motion of the mechanism shown in fig. 12, where B D A E C is a skeleton drawing of fig. 9, D E being the centre line of the slot. Now, it is required to find the point H where the centre line D E cuts the line of centres V O corresponding to the positions F G of the eccentrics on a full-size diagram. Cut out a template of the shape of fig. 10 to represent full size of the link where the points A B C (fig. 12) are the centres of the pins. This full-size template must be placed on the drawing in the positions successively assumed by the actual link in one complete revolution, and this without the assistance of the actual centres of the eccentrics. A, it is clear, must, when

in position, lie on an arc with L, fig. 12, as centre, B on an arc with F as centre, and C on an arc with G as centre, and the difficulty is to describe the arcs through B and C without the use of the centres F G. This is overcome as follows : Make a template of the shape of fig. 11 where MN is a circular arc whose radius = FB, and MP part of a radius. Make OO_1 , fig. 12, = FB, and describe a circle F_1G_1 equal to FG. It is clear that F must be a point on the required arc through B, for $FF_1 = OO_1 = FB$; hence we can use the template MNP as a set square is used, and draw off along MN the arc required, as at F_1B , fig. 12. Hence we see that we do not now require the centres FG, for we can draw any arc we require without them, and the template BAC can be easily adjusted as required, and the point H determined and marked on the paper. Thus the displacements of the valve are determined full size. All the constructions previously described can by this method be made full size.

The curves in fig. 13 have been obtained, as explained above, from a well-designed link motion to show how the cut-off, lead, travel, and slip vary for different mean positions of the die in the link. The length of the link is 18 in. The rods are crossed. The lap of valve is 1 in., and radius of eccentric $3\frac{1}{4}$ in. The scales to which the curves are plotted are also appended. It will be seen that all the curves are regular, with the exception of the slip curve, which is of a wavy shape. It will also be seen from the curves that the point of cut-off varies more rapidly near the centre of the link for a small motion of the link than near the ends; also that the lead increases as the link is raised, and that the slip is greatest near the ends of the link, diminishing to nothing near the centre. These curves give a very comprehensive notion of the action of this form of link gear.

JOY'S VALVE GEAR.

Joy's valve gear is one of the many methods of driving the valve without having an eccentric on the shaft. It is shown in outline in fig. 14. C R is the connecting rod, P

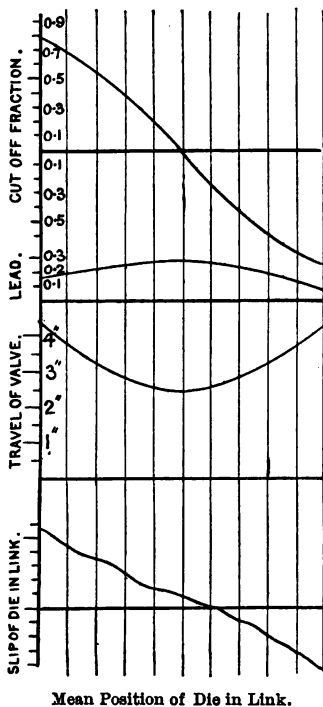

Mean Position of Die in Link.

FIG. 18.

is a fixed point, P Q a radius rod, Q L a rod connected to a point on the connecting rod, M is a point on rod Q L, M D a rod attached to this point, D is a die sliding in a circular slot A B, E is the point of attachment of the valve rod. As the connecting rod works, point E describes the elliptic figure shown. These figures may be found by straight-

forward constructions, as follows: Mark in successive positions of the connecting rod, and find point L on each of them. Cut the circle through Q with a circular arc of radius = L Q. Draw in the successive positions of this rod, and find point M on each of them. Cut A B with arc of

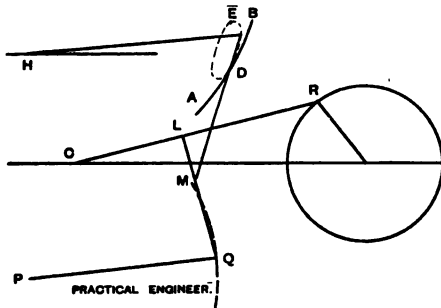

FIG. 14.

radius = M D, and draw in successive positions of this rod, and find point E on each of them. Then cut the line of centres V H by an arc of radius = rod E H. This gives the motion of a point H connected with the valve, from which the motion of the valve may be found. The valve position curve will be an ellipse, which must be treated as before.

CHAPTER III.

DIMENSIONS OF DETAILS.

GRAPHICAL methods can sometimes be employed to simplify the calculations necessary to determine the dimensions of other parts of simple engines than those already mentioned. Where the calculations are very simple, it is much quicker to adopt arithmetical methods, especially when a slide rule is used. A combination of the two in the more complex cases is easier and more rapid than either separately. The

use of very high pressure steam, which is now becoming so common, often makes it difficult or impossible to adopt such low values for stresses, pressures, &c., as are usually found in text-books. Considerations of appearance and economy enter so largely into design, that a draughtsman often has not as free a hand in determining dimensions as he might wish. There is no doubt that stresses in materials and pressures on bearings are regularly used, and with results perfectly satisfactory in every way, which are largely in excess of text-book values. For instance, a designer of very wide experience in marine-engine work, publicly stated not long ago that in calculating diameters of crank shafts, he found it sufficient to neglect entirely the bending moment on the shaft, while allowing the same stress in the material as is ordinarily allowed for this part. The effect of bending moment and twisting moment combined is always much larger than, and is often double of, that due to twisting alone, whence it appears that stresses of double the text-book values are sometimes used with good results. Though this appears a somewhat extreme instance, there is no doubt that if one could be sure that all materials were perfectly sound and free from flaws, very much higher values than are now used might be safely allowed in designing. Experience is, of course, the only reliable guide in determining how far it is safe to exceed ordinary values, when these are inconveniently small. It may, however, be stated generally that as low values should always be allowed for stresses and pressures as are consistent with economy and a good appearance. Large wearing surfaces tend to long life of the engine and low cost of repairs.

The following calculations and constructions show how to obtain the principal dimensions of an engine rapidly and easily, assuming ordinary high values for stresses and pressures. Given diameter of cylinder and length of stroke, determined as in article I., and length of connecting rod.

SIZE OF PISTON ROD.

Find area of piston in square inches ($D^2 \times 7854$). Multiply by the boiler pressure in pounds per square inch. This gives total pressure on the piston. The diameter of screw at the back of the piston should be

$$\sqrt{\frac{\text{Total force on piston in pounds}}{3400}}$$

This allows a stress of 6,000 lb. per square inch at the bottom of the thread.

Diameter of piston rod should be not less than

$$\sqrt{\frac{\text{Total force on piston}}{2800}}$$

which allows a stress of 3,500 lb. per square inch, a value which is found sufficient to allow for undeterminable strains, such as bending in the cylinder, due to presence of water, and bending due to the slide bar being slightly out of line.

AREA OF BEARINGS.

To obtain area of crank pin (*i.e.*, length \times diameter), set off the total force on the piston as at A B, fig. 16, to a scale of 500 lb. to 1 scale division. These divisions may be 1 in., $\frac{1}{2}$ in., 1 centimetre, or any other convenient size.

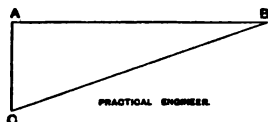

FIG. 16.

Draw a perpendicular A C from A. Make the angle A B C equal to the maximum inclination of the connecting rod. Then the area of the crank pin should be not less than the number of scale divisions in B C. This allows a pressure on the bearing of 500 lb. per square inch. A larger area than

this is very desirable if it can be obtained. Twice as much, or even more, is not too large, and can often be easily obtained with low pressures, though some authorities allow as much as 1,000 lb. The area of the crosshead pin should be not less than $\frac{1}{3}$ B C. The diameter of this pin is treated of later on. The area of the slipper should be not less than $4 \times A C$, measured by the assumed scale.

DIAMETER OF CRANK SHAFT.

To obtain the diameter of the crank shaft we must know the bending moment on it and the twisting moment. To obtain the former, calculate the probable position of the centres of the bearings (which should be as close to the crank pin as possible). After the crank shaft has been provisionally designed, it may be necessary to correct the construction if the position of the centres of the bearings is very different from this estimate. Set out these positions as at P Q R, fig. 17, to any scale where P and R are the bearings, and Q the line of stroke. Find the value of B C, fig 16, in tons. This is the force at Q. Multiply this force in

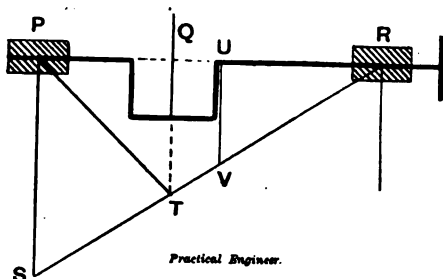

FIG. 17.

tons by the real length of P Q in inches, and set off the value so found to any convenient scale along P S. Join S R, cutting Q produced in T. Then Q T to scale represents the bending moment at Q in ton-inches. The vertical distance of the

line PTR from PR at any point represents the bending moment at that point. The process is similar if there is more than one force between the bearings, as in fig. 18, where A and D are the bearings, and B and C the forces.

Multiply force B in tons into AB in inches. Set off the value so found at AE. Multiply C in tons into AC in inches, and set off this value at EF. Join FD, cutting C

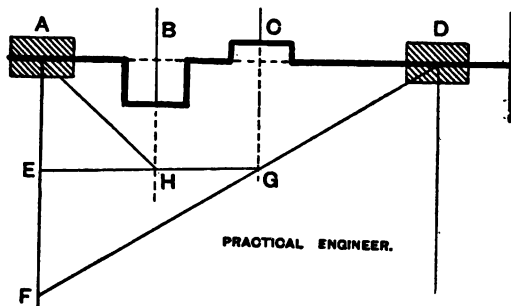

FIG. 18.

produced in G. Join EG, cutting B produced in H. Join AH. Then AHGD is the curve of bending moments on the shaft in ton-inches. We shall first deal with a single crank having a bearing at each end.

Having found the bending moment, find the twisting moment by multiplying the total maximum force in the connecting rod—i.e., BC, fig. 16, reduced to tons into the length of crank. Set off the length UV, fig. 17, as shown in fig. 19. The reason for UV, and not QT, being taken, will be presently explained.

Draw UM at right angles to it, taking UM equal to the twisting moment on the same scale as the bending moment scale. Describe a circle MN with VM as radius. Take UP = 10 in., and UR = 2.8 in. Join PN, and produce it to S, and draw RS horizontally. Then the length of RS, in the same units as the bending moments are measured in, gives

the value of d^3 where d is the diameter of the shaft required.

For instance, if the bending moments are set off to the scale of $\frac{1}{2}$ in. = 1 ton-inch, then, if RS measures 16 in., corresponding to 32 ton-inches, the cube root of 32, or, say, $3\frac{1}{2}$ in., will give the necessary diameter of shaft, allowing 4 tons per square inch on the steel of which the shaft is made.

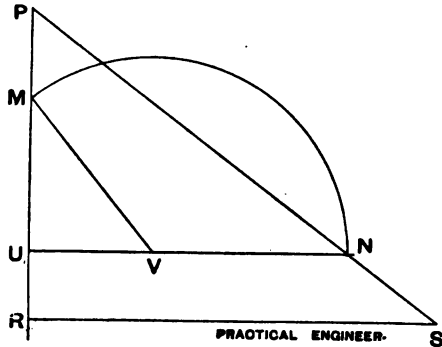

FIG. 19.

This construction is a convenient way of solving the two equations—

$$T_e = M + \sqrt{M^2 + T^2} \dots \dots \dots (i)$$

and
$$T_e = \frac{\pi}{16} q D^3 \dots \dots \dots (ii)$$

where T_e represents not the actual twisting moment urging the crank shaft forward, but an imaginary twisting moment which would produce the same stress in a shaft as a bending moment M and a simple twisting moment T combined, q being the stress on the shaft (here assumed as 4 tons per square inch), and D being the diameter of shaft. It is clear that

$$VM = \sqrt{M^2 + T^2},$$

and therefore $UN = M + \sqrt{M^2 + T^2} = T_e$;

$$\begin{aligned}
 \text{also} \quad R S &= T_e \times \frac{12.8}{10} \\
 &= T_e \times 1.28 \\
 &= T_e \times \frac{4}{\pi} \\
 &= D^3
 \end{aligned}$$

from equation (ii.) above, after substituting 4 for q .

Of course, M and T are the *simultaneous* values of the bending and twisting moments respectively. If the valve gear is so designed as to always cut off steam before half stroke, it will be necessary, in case the weight has to be kept down, to find the point of the stroke at which $M + \sqrt{M^2 + T^2}$ has its greatest value. It is clear that the pressure on the piston falls considerably when the steam expands. Now, the bending moment is only dependent on the total pressure on the piston and the relative position of the bearings and line of stroke, as seen in fig. 17. It does not in the least depend on the angle which the crank makes with the line of stroke, except in so far as this latter affects the total pressure on the piston. Thus the value of M diminishes as the steam expands, being in all cases directly proportional to the total pressure. But the value of T may and does increase considerably, in spite of the diminishing pressure, because during almost the whole of the first half of the stroke the leverage at which the push of the connecting rod acts is increasing more rapidly in proportion than the total pressure is diminishing.

If $O P$, fig. 20, represents the position of the crank at any time, then the twisting moment on the crank shaft at that instant = force in $C P \times$ real length of $O K$, where $O K$ is the perpendicular on $C P$ produced. The force in $C P$ must be found by the method explained in connection with fig. 17. The constructions already explained are so easy and rapid, that the value of T_e can be quickly calculated for half a dozen positions at the crank in the first half of the stroke, where its value will be greatest, from the hypothetical

indicator card, as shown in fig. 1. These values of T_e should be plotted either on a base of piston positions, or on a base representing the crank circle unrolled. The latter is perhaps better. A smooth curve drawn through the points will show very accurately the maximum value of T_e , which should, of course, be used in calculating the diameter of the shaft. No point on this curve need be found corresponding to a position of the crank before cut-off takes place, for it is clear that the value of T_e at cut-off will be greater than any value it can have before that point, because, while

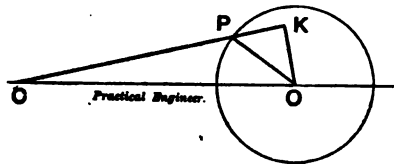

FIG. 20.

M is constant during admission, T_e is constantly increasing during that period; so that $M + \sqrt{M^2 + T^2}$ must be greater at cut-off than at any previous time. More complicated examples of crank shafts will now be considered.

The calculation becomes somewhat complex, though quite easy, if there are two or more cranks using expansion between the two bearings. In this case curves of bending moments must be drawn, as explained in connection with fig. 18, for several positions of the crank shaft. As regards the twisting moments, it must be borne in mind that any twisting moment generated in the shaft by *any* of the cranks is transmitted undiminished along the whole length of the shaft between the point where it is generated and the point where the power is drawn off.

Thus, if fig. 18 represents a skeleton of a shaft which has two cranks at right angles, driving, let us say, a centrifugal pump through a coupling, then the twisting moment

generated at B is transmitted as a twisting moment along the shaft between B and C, through the crank pin C, still existing in that pin as a twisting moment (assuming rigidity of the shaft) in spite of the fact that the pin C is out of line with the shaft (since a couple is equivalent to any other couple of equal moment which has its axis parallel to that of the first couple), along through the bearing D to the coupling, where it is resolved into pairs of shearing forces on the coupling bolts, beyond which it again becomes a twisting moment in the pump spindle. Now, the twisting moment generated at C does not appear as a twisting moment until it reaches the shaft between C and D. In the pin C there can be no twisting moment due to the force C, because to produce a twisting moment we must have two equal and opposite couples, one at each end of the shaft. There is no opposing couple at the other end of the shaft, and therefore there can be no twisting moment in C, except that due to B's action on the one side and the resistance of the pump on the other.

The magnitude of the twisting moment in pin C will be the twisting moment generated by B, since the other part of the total twisting moment in the pump spindle does not exist as a twisting moment further to the left than the right-hand crank cheek of C. A little consideration will enable us to dispense with a large part of the work in finding the most strained section. The crank shaft will probably be of constant size (from considerations of symmetry) all along its length; hence we can at once infer that since B and C are exactly alike, and since B has no twisting moment on it at all, while C has the twisting moment due to B, and, in addition, the same bending moment that B has (probably, but of course it depends on the position of the bearings, and on the proposed indicator cards), that therefore B is not the most strained section. We can therefore neglect B altogether, and confine ourselves to the part of the shaft between B and C, the pin C, and the

shaft to the right of C. Where the shaft is very large, and where lightness is important, it is sometimes necessary to increase the diameter at the parts where the value of T_c is greatest. When this is the case, it is easy to find the diameter all along the length of the shaft to secure equal stress at every part.

To draw the curves for one position of the cranks for a vertical engine, determine, as in fig. 21, the position

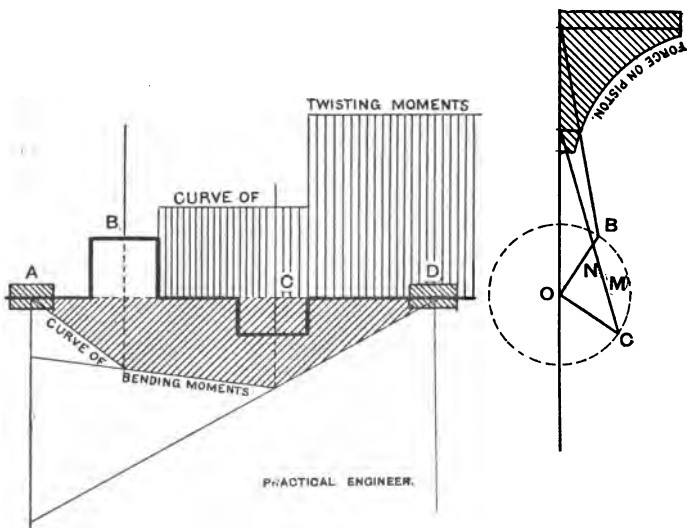

FIG. 21.

of the crossheads corresponding to the position of the cranks given. Find, as in fig. 17, the load on the connecting rods, and draw the bending moment curve (obliquely shaded in fig. 21), assuming both loads vertical. This is sufficient to secure a margin of safety. The exact state of bending stress in the shaft, excluding twisting strains, due to

loads not in the same direction, is somewhat complicated, and need not be taken into account in practice.*

It can easily be shown, that when the inclination of the rod is not large, it is sufficient to take both loads as vertical to secure sufficient strength.

Next draw the twisting moment curve by calculation. It consists in this case of only two steps, and is easily drawn. The height of one step is the T M, due to B in the position shown, while in the other the height is the joint effect of B and C.

These are, of course,

$$T_A = \text{force in connecting rod B} \times O M.$$

$$T_B = T_A + \text{force in connecting rod C} \times O N,$$

where M and N are the feet of the perpendiculars (not shown in fig. 21) from the centre of the shaft on the connecting rod produced.

It is easy to select from this diagram the two or three positions at which the value of T_e might be a maximum. Such as—

- (1) A point to the immediate right of crank C.
- (2) A point to the immediate left of crank C.
- (3) A point in the middle of crank pin B where there is bending moment alone.

Draw the diagram for T_e for each of such points, and find which is greatest. Do the same for several positions of the

* It is, however, very interesting, being somewhat as follows, as may be seen by anyone who analyses it carefully. It consists in the vertical plane of a varying bending moment all along the shaft. Between A and B the bending moment is sometimes pure and free from shear—*i.e.*, when both cranks are on the same (positive or negative) side of the line of centres, and before cut-off has taken place in either cylinder. When cut-off takes place in the leading cylinder, the B M becomes impure between A and B—*i.e.*, vertical shear is introduced, which varies from positive to negative twice in each revolution. Outside A and B the B M is always impure. Roughly speaking, one side of the shaft—*i.e.*, the crank side—is always in tension, while the other is always in compression. In a horizontal plane there is also in general a varying bending moment, which can never be pure, except in one position when cut-off is very late. Between A and B there may be pure shear in the horizontal plane near the ends of the stroke if the valves have sufficient lead.

cranks, judiciously selected, and take the maximum value of T_c for the necessary calculation for the diameter of shaft. The whole of this process, though somewhat tedious to describe, can really be effected with great rapidity if it be thoroughly understood.

In the case of overhung cranks the bending moment and twisting moment are both greatest at the centre of the bearing nearest the crank. This is, therefore, the section to be considered. The value of the bending moment is force in connecting rod \times perpendicular distance of centre line of stroke from centre of bearing.

The twist and bending moments are combined, as before.

If the weight of a flywheel has to be taken into account, it must be treated in exactly the same way as a force in a connecting rod.

LOCOMOTIVE CRANK SHAFT.

In the case of a locomotive crank shaft we have to deal with an additional bending moment in a vertical plane, due to that part of the dead weight of the engine which rests on the driving axle. The cylinders are here horizontal, or nearly so, and the thrust of the connecting rods act on the shaft in a direction almost at right angles to the shaft and to the force due to the weight of the engine. We have, therefore, to find the maximum resultant of two bending moments, whose axes are inclined at a variable angle. By the axis of the bending moment is meant the *direction* of the axes of the equal and opposite couples, which, acting at opposite ends of the shaft, produce the bending moment between them, or, in other words, the direction of any line at right angles to the plane of these couples.

Now, between W_1 and W_2 , fig. 21A, the bending moment in the vertical plane is constant, and the section on which the greatest stress will come will therefore be that section which has the greatest bending moment in the horizontal or other plane due to the connecting-rod thrust. Now,

suppose the connecting rods are both inclined upwards and are in thrust. It is clear that the tendency of the upward thrust is to counteract some of the downward bending moment due to the weight of the engine. For a similar reason the downward bending moment will be a maximum either when both rods are inclined downwards, and are at the same time in compression (as will be the case when the engine is being driven forwards), or when both are inclined upwards and are in tension. But since the axes of the cylinders are usually slightly inclined downwards, it is

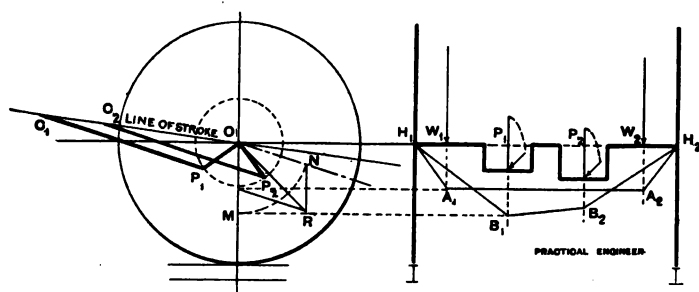

FIG. 21A.

clear that the former will be the position of greatest bending moment in a downward vertical direction.

When the cranks are equally inclined to the line of stroke, as in fig. 21a, there will be the same stress in the connecting rods in the same direction, and this will be the position of greatest bending moment. Now, we can draw a bending moment curve, as already explained, due to dead-weight forces in the vertical direction, and another due to forces parallel to $C_1 P_1$. The former should be imagined drawn in a vertical plane, and the latter in the plane containing $O N$ (parallel to $C_1 P_1$) and the axis of the shaft. If this latter plane be turned about the axis of the shaft into a vertical plane, this curve will appear as at $H_1 B_2 B_1 H_2$, while the "vertical force" curve will

appear as H_1 , A_1 , A_2 , H_2 . It is clear, then, that both bending moment curves may be drawn in the front elevation, and their heights transferred, as shown, to their proper planes on the end elevation, as at $O N$, $O A$. Now, the resultant of these two, as at $O R$, will give the resultant bending moment in magnitude and direction. This must therefore be used in calculating the diameter of the shaft.

SIZES OF BOLTS.

In determining the sizes of the various bolts and screws used to connect the different parts, the section to be considered is that at the bottom of the thread, on which section a stress of three tons per square inch is commonly allowed in those cases in which the stress varies from zero to a maximum. The diameter at the bottom of the thread is very nearly $0.85 \times$ diameter of bolt. Hence, when a force varying from 0 to f tons has to be resisted by a bolt, the full diameter of bolt necessary is

$$d = 0.77 \sqrt{f},$$

where f is in tons. This can easily be obtained from the formulæ—

$$f = q \times \frac{\pi}{4} d_1^2,$$

and

$$d_1 = 0.85 d,$$

where the stress

$$q = 3 \text{ tons per square inch.}$$

If the screw is likely to be twisted much, as in the case of the studs of a cylinder cover,

$$d = 0.85 \sqrt{f}$$

Very small bolts or studs, less than $\frac{5}{8}$ in., should be avoided, if they have to be tightly screwed up, as they are likely to suffer more than larger ones from injudicious treatment at the hands of a workman. The largest bolt or stud that can be used consistently with good appearance and convenience should always be put in. The above values should be considered as the smallest that can safely be used in

positions where sudden stresses are likely to come on them. In case the bolts are to be under constant tension, the stress allowed is usually 4 tons. In this case $d = 0.66 \sqrt{f}$. *The Practical Engineer Pocket-book* contains a most useful table giving the necessary sizes of bolts for different stresses and loads.

Where it is possible, bolts should be turned down in the shank to the diameter at the bottom of the thread of the screw. The bolt is thereby rendered less likely to break, for the following reason. If a bolt be accidentally subjected to a larger load than it can bear, the greatest stress will, of course, come on the section at the bottom of the lowest thread. The bolt will therefore stretch at this part, while the shank of the bolt will retain its original length. If the force be increased till this section gives way, the bolt as a whole will only have stretched a very small distance before breaking takes place at this section. Now, if the shank of the bolt be turned down, as described, stretching will take place equally along its whole length, and the work necessary to break it will be much increased, because it will lengthen much more before breaking than if it had not been turned down.

CAPS.

The next point to be considered is one which is frequently overlooked in engine design, viz., that the caps of all bearings should be strong enough to resist all bending moments which are likely to come on them. Caps are really in the position of little beams loaded in the middle and supported at the ends. Designers, judging from the breadth and general appearance of these caps, frequently take it for granted that they are strong enough to take their load forgetting that the strength of a beam depends far more on its depth than on its breadth.

The bending moment on a cap in ton-inches can easily be found by the method of fig. 17. It is necessary to add that the brass is not usually strong enough to take any of the

bending moment, because brass is expensive, and it is therefore usual to keep it as thin as possible. The whole load then comes on the middle of the iron or steel cap. The cap is usually of flat rectangular section, both for the sake of appearance and cheapness.

A method of testing a proposed section for strength is as follows: Find the bending moment on it in ton-inches by the method of fig. 17, where P and R are the centres of the bolts and Q the load. Then draw the section full size, if rectangular or nearly so, as at A B C D, fig. 22. Mark off A E = 1 in. Join D E, and produce to G. Draw G K L horizontal and D L perpendicular to D G. Then, if L K,

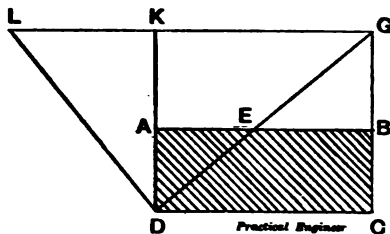

FIG. 22.

measured in inches, is less than the B.M. just found, the section, if of steel, is too weak. If of cast iron, the B.M. should be not greater than one-fifth of K L. This is a graphical method of applying the formula $M = f Z$ for the strength of a section under bending stress where $Z = \frac{b d^2}{6}$ for a rectangular section. For the formula becomes $M = 6 \times \frac{b d^2}{6} = b d^2$. In fig. 22 $CG = b d$, for by geometry $AD \times DC = AE \times DK = CG$, and $LK = b d^2$, because $DK \times DA = LK \times AE = LK$. The stress allowed is here about 13,500 lb., or 6 tons per square inch, which is the limit which should not be exceeded for steel, while one-fifth of

this value, or 2,700 lb., is the limit for cast iron under similar conditions.

CROSSHEAD PIN.

The crosshead pin is also a small beam, under similar conditions to the above, as regards stress. It is, however, usually backed up by a brass brush, which is supported at the back by the crosshead, and the load on it is probably more uniformly distributed than is the case, for instance, with the connecting-rod cap. But if the crosshead pin bends appreciably, even though it be amply strong enough, the pressure on the outer parts of the

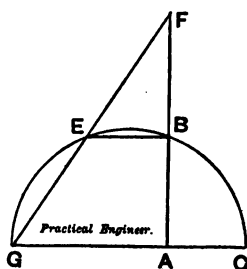

Fig. 23.

bearing becomes very much intensified, and this may give trouble by causing the bearing to heat. The following construction allows a stress of 13,500 lb. per square inch on the pin, assuming the load concentrated at the centre, and gives good results for a steel pin.

Find the bending moment as before. Set up AB , fig. 23, equal to the diameter of the pin. Make $AC = 1$ in., and describe a semicircle passing through C and B , whose centre is on AC produced. Make BE parallel to SC , cutting the semicircle at E . Draw the line GEF . Then the line representing the bending moment in ton-inches should be not greater than $\frac{2}{3}$ of AF . If it be greater than this, the

diameter of the pin must be increased. In this construction $GA = d^2$ and $AF = d^3$, as may easily be proved geometrically.

Of course, the pressure per square inch on the bearing—
i.e.,

$$\frac{\text{total force in connecting rod}}{\text{length of pin} \times \text{diameter}}$$

must, as already explained, be kept below a maximum of 1,400 lb. This construction only tests whether the diameter of the pin is great enough to resist bending stresses. It is a graphical translation of the formula $M = fZ$, where

$$Z = \frac{a^3}{10}$$

allowing, as before, a stress of 13,500 lb., or 6 tons per square inch, on the pin, which in good engines is usually made of crucible steel.

ECCENTRICS.

The minimum diameter of the eccentric sheave is determined by the stroke of the valve and the radius of the shaft as follows: The radius of the sheave should be so great that the thickness of the sheave (between the surface of the shaft and that of the sheave) at its thinnest part should be strong enough. When the eccentric is made in two parts, the smaller of the two is usually made of wrought iron or steel, so as not to unduly increase the diameter of the sheave; when this is the case, the smallest thickness should be $\frac{3}{4}$ in., so that minimum radius of sheave

$$= \text{half-stroke of valve} + \text{radius of shaft} + \frac{3}{4} \text{ in.}$$

The breadth of the bearing surface is usually about one-fifth of the diameter of the sheave.

The eccentric is the part of the engine which most frequently gives trouble by heating. This is usually due to one of the following causes, if the workmanship is good:—

1. Inefficient lubrication.
2. Strap not stiff enough, causing binding of the strap on the sheave.

3. Too great pressure per square inch on the strap.

In designing eccentrics it is necessary to bear these in mind :—

1. Automatic lubrication is almost invariable in high-class engines.

2. The radial depth of the strap should be so great that the bending moment on it produces a stress of not more than half a ton per square inch in the material. This condition will be usually fulfilled if the depth of the strap in a radial direction is from $\frac{1}{2}$ to $\frac{3}{4}$ of the width of the eccentric.

3. The pressure per square inch is

$$\frac{\text{total load on eccentric rod}}{\text{diameter of sheave} \times \text{width}}$$

This should not be greater than 80 lb. or 100 lb. per square inch.

The load on the rod is due to the friction of the slide valve. It is usually taken as

= area of valve \times steam pressure \times coefficient of friction, which latter is usually assumed as 0.1.

It will usually be found that the proportions given above will fulfil this condition.

Valve-rod Pin.—This is the part of the engine which usually first shows signs of wear. Unless it is made fairly large, it wears loose in a very short time. It is often not well lubricated. In good engines it is usually made of crucible steel. The pressure per square inch on it (estimated as above from the pull in the eccentric rod) should always be below 500 lb.

It will be observed that in the above rules the minimum areas of all the bearings have been determined solely from the pressures per square inch, the velocities of rubbing being disregarded. Elaborate rules are often given, according to which the product of the pressure per square inch and the rubbing velocity should be an arbitrary constant, which constant varies for different classes of bearings. Though in theory this rule is reasonable enough, it is utterly

impossible to adhere to it even approximately in practice. The most that can be done is to keep the pressures per square inch as low as possible when the speed is high. Any attempt to formulate a general rule on this principle results either in a cumbersome and useless multiplication of symbols, coefficients, and tables, or in results which are ridiculously at variance with practice, and often both, as the following example (taken from an engine now working satisfactorily) will show. The dimensions of the engine are : Cylinder 27 in. diameter, 20 in. stroke, crank pin $7\frac{1}{2}$ in. by 10 in., area of valve $25\frac{1}{2}$ in. by $15\frac{1}{2}$ in., maximum revolutions per minute 180. Some works on machine design give some such rule as the following :

$$\text{Minimum width of eccentric} = 2 \frac{p a N}{170000}$$

where

p = steam pressure,

a = area of valve,

N = revolutions per minute.

This, along with other rules derived from it, results in an eccentric 80 in. wide by 120 in. in diameter (!), and eccentric bolts about 3 ft. in diameter (!!). Other rules founded on the same theory would give the crank pin an area of about 280 square inches, or 28 in. long by 10 in. diameter. Such proportions are obviously absurd in practice ; therefore it seems necessary to be rather less ambitious, and to use rules somewhat less theoretically perfect. The practical rule is, briefly : Keep the pressures per square inch as low as possible, especially for high speeds, but always below certain maxima, which differ for different classes of journals.

CHAPTER IV.

COMPOUNDING.

THE use of high pressures, which is now becoming so common, makes it difficult to use steam to full advantage in a single cylinder. The following are the chief reasons for this :—

(i.) High-pressure steam acting on a moderately large piston requires the use of very large and heavy details in order that the stresses and pressures, &c., may not be excessive at certain parts of the stroke. These are ugly to look at, unwieldy to handle, and expensive to make. Their great weight and inertia produces excessive vibration, thus increasing the expense of necessary foundations. Compounding, as will be presently explained, considerably reduces all these evils.

(ii.) The great variations in the pressure in the cylinder which is necessary if the steam is to be adequately expanded causes excessive inequality in the driving force, thus rendering a very heavy flywheel necessary to keep the speed constant.

(iii.) The great variation in pressure also causes a great variation in temperature in the cylinders, causing large waste of steam by condensation, with its accompanying evil of collection of water in the cylinder.

For these and other reasons it has been found economical to expand the steam in two or more cylinders successively. These can be arranged in a great variety of different ways. We shall here show methods of treating several representative cases. All others may be treated in the same manner.

In designing a compound engine, the first thing to determine is the volume of the L.P. cylinder, for this fixes the power of the engine. The latter is not (within certain limits) dependent on the size of the H.P. cylinder, provided that is large enough to contain all the high-pressure steam

used in one stroke. In fact, the diameter of the H.P. cylinder may vary very considerably without having much effect on either the power or the economy of the engine. This point will be presently discussed.

The method of determining the volume of the L.P. cylinder is identical in principle with that already described in Chapter I., which it is advisable to read carefully before commencing the following explanation: The size of the L.P. cylinder of a compound engine is almost the same as, but slightly greater than, would be required for a single engine giving the same power, and using the same ratio of expansion. The reason for this is as follows: If a given quantity, say 1 lb., of steam or any other gas expands continuously between two given volumes, say 2 cubic feet and 17 cubic feet, without gaining or losing heat otherwise than by changing it into work done, then the amount of work done (in foot-pounds) by the steam on the pistons or other moving pieces is the same, however this expansion may have taken place. Thus, if a volume v_1 of steam could be partly expanded in one cylinder to volume v_2 , and then be transferred *unaltered in volume* to another cylinder of different diameter, and further expanded to volume v_3 , and so on for several stages till it reached the volume v_f , then the total aggregate work which would have been done on all the pistons together would be precisely the same as if the whole of the expansion had taken place in a single cylinder between the same two volumes v_1 and v_f .

This can easily be proved by calculating the actual quantity of work done in each cylinder by the method of Chapter I., and adding them together. Thus, in this case, work done during expansion in first cylinder—

$$p_1 v_1 \log_e \frac{v_2}{v_1};$$

work done during expansion in second cylinder—

$$p_2 v_2 \log_e \frac{v_3}{v_2}, \text{ \&c. \&c.}$$

The work done in the second cylinder is $K J E H$, and so on. It is clear that the sum of all such areas is the same as $F M N B$, which would have been the work done if all the expansion had been performed in a single cylinder. It is also clear that the volume of the L.P. cylinder—i.e., $A N$ —is the same as the volume of the single cylinder would have been; also that the maximum pressure per square foot in the single cylinder (on which, of course, the size of the details of the engine depends) is $B F$, whereas in the assumed L.P. cylinder it is only $E J$.

Now, the chief difference between this ideal case and the actual method which is used in a compound engine consists

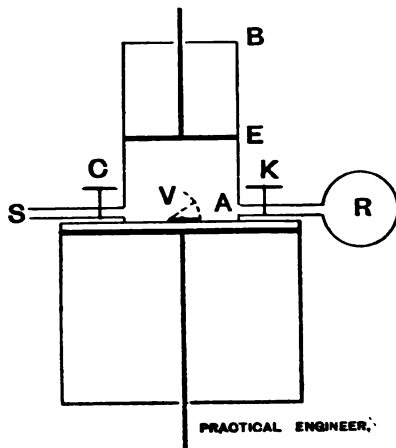

FIG. 25.

in the effect of the practical method of transferring the steam from one cylinder to another, and the work done during that transference. It is, of course, impossible in practice to take the steam bodily, as we have assumed, and carry it to the second cylinder unaltered in volume; we must of necessity allow it to flow through pipes. But these

pipes have of necessity a certain volume, and it is therefore clearly impossible to allow the steam to directly enter the second cylinder unchanged in volume. In order to understand the relation of the ideal method to the practical, consider two cylinders joined together, as shown in fig. 25. Let S be the pipe leading from the boiler, and C the admission valve. V is a valve by which communication can be made between the two cylinders. R is a receiver or box provided with a valve K. The use of this will be presently explained.

Suppose both pistons are at the inner ends of their respective cylinders.

(i.) Admit steam to the H.P. cylinder from the boiler at a pressure of, say, 120 lb. absolute till the H.P. piston has reached E.

(ii.) Shut off steam, and allow the steam in the cylinder to expand to the end of the stroke. Steam expands very nearly according to the law that pressure \times volume = constant. Its pressure, therefore, at the end of the stroke is $120 \times \frac{A E}{A B} =$ let us say, 55 lb. per square inch.

(iii.) Now open valve V, and let both pistons descend in such a way that the volume of the steam between the pistons is unchanged till the end of the down stroke of the small piston.

(iv.) Shut valve V, and allow the steam in the large cylinder to expand to the end of the stroke.

(v.) Exhaust the steam in the L.P. cylinder into the condenser, allowing the piston to return to its original position.

Now, if this engine had been "indicated" during this process, the cards which would have been produced (after the H.P. card had been reduced to the same scale of volumes as the L.P. card) would be as shown in fig. 26. (i.) The work done on the H.P. piston during admission would have been A B H G. (ii.) The work done during H.P. expansion would have been B C K H. (iii.) During this operation the work done against "back pressure" by the H.P. piston would have

been D C K G. Now, exactly this same amount of work is at the same time done by the steam on the L.P. piston during the process of pushing back the H.P. piston. In fact, during the process of pushing back the H.P. piston the steam acts in the same way as the water in a Brahma press. It is the medium through which the work done on the H.P. piston is transferred to the L.P. piston. It is thus clear that the net amount of work done by the steam on the H.P. piston is ABCD. (iv.) During this operation the amount

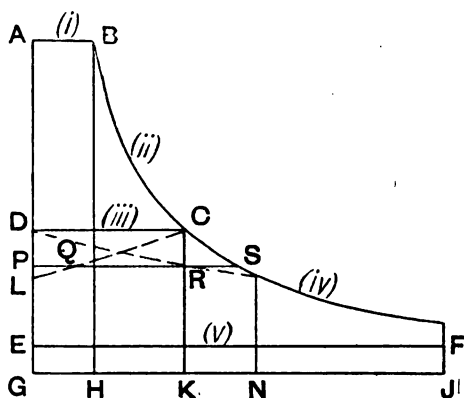

FIG. 26.

of work done on the L.P. piston is CFJK (v.). The work done against back pressure by the L.P. piston on the return stroke is EFJG. Therefore, the total net amount of work done on the L.P. piston is DCFE, where EF is a line whose height represents the condenser or back pressure. Such an engine as this would theoretically be an ideal compound engine, as far as an unjacketed engine can be. A receiver engine with cranks at right angles will be shortly discussed. But the only practical mechanism we can use for controlling the relative motion of the pistons is the crank connecting-rod mechanism, which does not allow of this ideal motion of the pistons being realised. Both pistons

must move backwards and forwards with a distorted simple harmonic motion. This, however, of itself would not of necessity involve loss of power if there were no space between the cylinders, and if the passage between them were of ample area, because the expansion of the steam would still be continuous. It would mean that instead of producing two cards which fit exactly together along D C, as in fig. 26, we should have two as shown in dotted lines A B C L and D M F E. Now, this division of the card tends to conceal from the reader the real continuity of the expansion during the process of transference. This he can see by considering the real relation of the two curves C L, D M.

If we take a horizontal P Q R, cutting both curves in Q and R, then Q and R represent the simultaneous state as to volume and pressure of the steam in the low and high pressure cylinders respectively. At this particular instant P Q represents the volume of the steam in the H.P. cylinder, P R the volume in the L.P. cylinder, and G P the common pressure. These volumes are always such that $PQ + PR = PS$. This fact shows the continuous character of the expansion—that is to say, that the steam does not, at any part of the stroke, suddenly expand without doing work.*

If the indicator card, such as fig. 26, of the expansion be considered as a whole—i.e., whole volumes horizontal, pressures vertical—the area C M N K represents the net work done during the transference. It is equal to the difference between the areas D M N G and L C K G. Also the sum of the areas A B C L and D M F E = whole area A B F E, all of which propositions can easily be proved analytically.

* It needs some grasp of the principle of the conservation of energy to appreciate thoroughly the proposition that if steam expands continuously—i.e., without any sudden jumps—a corresponding net amount of mechanical work must be communicated to the moving piece whose motion causes the expansion. In this case it is, of course, the pistons.

To explain the action of the intermediate pipes, imagine that before operation (iii.) in our ideal engine, instead of allowing the steam then in the H.P. cylinder to expand continuously, we had opened cock K. This operation we shall call (ii.)*a*. The immediate result of this would have been a fall of pressure in the H.P. cylinder, and therefore lower pressures during operations (iii.) and (iv.). In (iii.) there would have been no loss of work due to this cause unless expansion had taken place simultaneously with the process of transference, but in any case there would be less work done during the whole of operation (iv.), because, although the product pv might remain the same if valve V were left open, the ratio of expansion during (iv.) would have been lower, and therefore $pv \log_e r$ (iv.), which represents the work done during (iv.), would be smaller than if no expansion had taken place into R. As a matter of fact, valve V is not left open in practice, for reasons which will be presently explained, and therefore pv is diminished, although r remains the same as before when V is shut after (iii.).

Observe that we might have avoided this loss of pressure if the initial pressure in R before K was opened had been the same as the final pressure in the H.P. cylinder. Methods of securing this condition will be presently explained. If the pressure in R be less than this, the result will be a drop of pressure. It is, however, supposed that a small drop of pressure due to R is actually conducive to economy on account of the tendency of the sudden expansion to dry the steam, thus making it more effective in the subsequent expansion.

It is customary to calculate the value of this loss of pressure from the following assumption:—

- Let $V_R P_R$ be the volume and initial pressure in R;
- $V P$ be the final volume and pressure in the
H.P. cylinder;
- $V_F P_F$ the resulting final volume and common
pressure;

then it is assumed that, according to the expansion law,

$$V_F P_F = V_R P_R + VP;$$

but since $V_F = V_R + V,$

therefore
$$P_F = \frac{V_R P_R + VP}{V_R + V}.$$

If, however, the hyperbolic relation be an accurate expression of the law connecting the pressure and volume of expanding steam doing work during expansion (which, of course, it is not), it is clear that the same law cannot hold for steam expanding without doing work. It is, however, found to be near enough for ordinary purposes, and we shall, therefore, assume it in subsequent calculations.

It is thus seen that the effect of intermediate clearance is to diminish the effective power of the engine. Experience has shown that the loss due to this and other causes such as wire-drawing, &c., can be very approximately estimated as a percentage of the total theoretical power of the engine, which percentage varies for engines of different types. The rule in approximate design is, therefore: Add a certain fraction (given in column three below) to the work required to be indicated per stroke, and calculate the volume of a single cylinder required to give this power, the ratio of expansion being such as to leave the final pressure about

20 lb. per square inch for non-condensing engines;

10 lb. " " condensing "

The following are safe percentages to assume:—

Type of engine.	Percentage of nominal power actually obtained.	Fraction by which required work is to be multiplied.
	Per cent.	
Tandem with jacket.....	80	$\frac{5}{4}$
Tandem without jacket.....	75	$\frac{4}{3}$
Receiver engine—cranks at right angles with jacket.....	90	$\frac{10}{9}$
Receiver engine—cranks at right angles without jacket.....	80	$\frac{5}{4}$
Triple engines jacketed.....	75	$\frac{4}{3}$

These values have, of course, nothing to do with mechanical efficiency, which must be allowed for separately.

In illustration, take the case of a tandem engine jacketed. Boiler pressure 125 lb. per square inch absolute. Indicated work required per stroke (not per revolution) 2,500 foot-pounds. Here the nominal work per stroke must be

$$\frac{2}{3} \times 2500 = 3125.$$

Hence we have for volume (v) of L.P. cylinder

$$3125 = 1440 \times v (1 + \log_e 12) - 576 \times v,$$

whence

$$\begin{aligned} v &= \frac{3125}{1440 \times 3.485 - 576} \\ &= \frac{3125}{5030 - 576} \\ &= \frac{3125}{4454} \end{aligned}$$

$$v = 0.7 \text{ cubic foot, nearly.}$$

Having thus made a provisional determination of the total ratio of expansion and the volume of the L.P. cylinder, we can determine, as before, its diameter and stroke. Suppose the stroke is to be 10 in., the volume being 0.7 cubic feet = 1,210 cubic inches; the area of piston must be 121 square inches, which is almost the area of a $12\frac{1}{2}$ in. circle (see *The Practical Engineer Pocket-book*, page 29). We now proceed to determine provisionally the diameter of the H.P. cylinder.

It has been already pointed out that this diameter may vary very considerably without having a great effect on either the economy of or the total power developed by the engine. Mechanical considerations, however, such as the desirability of uniformity of pressures and constancy of twisting moments, dictate that, as far as possible, the power developed in the two cylinders should be the same; also, since great variations of pressures, and therefore of temperature, in any one cylinder cause great loss by condensation, it is evidently desirable that the maximum difference of temperatures—i.e., those of the boiler steam and the exhaust—

should be equally divided between the two cylinders. These two considerations should finally determine the diameter of the H.P. cylinder.

We can at once find the volume of fresh steam which is to be admitted to the H.P. cylinder every stroke. This is

$$\frac{\text{volume of large cylinder}}{\text{ratio of expansion}} = \frac{1210}{12} = 101 \text{ cubic inches,}$$

as will be shortly explained. Thus, when we have found the volume of the H.P. cylinder, we can at once determine the point of cut-off in it.

If we draw a diagram such as fig. 26, and divide it by a horizontal line CD in such a way that it is approximately divided into two equal parts, then the two diagrams thus produced would be the indicator cards from the two cylinders if they were of the ideal description explained in connection with fig. 25, and the length of the line CD would, of course, give the required volume of the H.P. cylinder. We can, however, find the volume on this assumption much more easily by calculation.

Let r be the ratio of expansion in the H.P. cylinder. The volume of this cylinder is then $101 \times r$ cubic inches. The area of H.P. indicator card must represent $\frac{3125}{2}$ foot-pounds of work = 18,744 inch-pounds.

This area is also represented by

$$p v_a (1 + \log_e r) - p_b v_h \text{ (see Chapter I.),}$$

where

$$p = \text{initial absolute pressure} = 120 \frac{\text{lb.}}{\text{in}^2};$$

$$v_a = \text{admission volume} = 101 \text{ cubic inches};$$

$$p_b = \text{back pressure};$$

$$v_h = \text{volume of H.P. cylinder};$$

hence

$$18744 = 120 \times 101 (1 + \log_e r) - p_b v_h.$$

But, by the properties of an hyperbola,

$$p_b v_h = p v_a = 120 \times 101 \text{ inch-pounds};$$

hence

$$18744 = 120 \times 101 \log_e r ;$$

therefore

$$\log_e r = \frac{18744}{120 \times 101} = 1.54 ;$$

therefore $r = 4.75$ (see *The Practical Engineer Pocket-book*, page 106).

$$v_h = 4.75 \times 101 = 476 \text{ cubic inches,}$$

which gives a ratio of volumes of the two cylinders of

$$\frac{1210}{476} = 2.55.$$

The corresponding range of temperatures would be

$$\text{H.P. } 341 \text{ deg. to } 240 \text{ deg.} = 101 \text{ deg.,}$$

$$\text{L.P. } 240 \text{ deg. to } 162 \text{ deg.} = 78 \text{ deg.}$$

(See *The Practical Engineer Pocket-book*, page 107.)

In practice, if we had a ratio such as this, the back pressure in the H.P. cylinder would be much less than $\frac{120}{4.75} = 25.5$, which is the value here assumed for it. The result would be that much more work would be indicated in the H.P. than in the L.P. cylinder.

Now, if we make equality of temperature range the basis of our calculation, we shall proceed as follows, taking the values from the table above referred to:—

$$\begin{aligned} \text{Total range of temperature } 341 \text{ deg. to } 162 \text{ deg.} &= 179 \text{ deg.,} \\ \text{half range} &= 90 \text{ deg.} \end{aligned}$$

Therefore range in H.P. cylinder 341 deg. to 251 deg. —

$$\text{corresponding to absolute pressures } 120 \text{ to } 30 \frac{\text{lbs.}}{\text{in}^2}$$

$$\text{Ratio of expansion in H.P. cylinder} = \frac{120}{30} = 4.$$

$$\text{Volume of H.P. cylinder } 101 \times 4 = 404 \text{ cubic inches.}$$

$$\text{Ratio of cylinder volumes} = \frac{1210}{404} = 3, \text{ about.}$$

Both these calculations are based on the assumption that there are no intermediate pipes. But owing to ignorance of the effect of intermediate clearance, which we cannot estimate at this stage of the calculations, we are obliged in practice to rely on previous experience for a provisional determination of the H.P. cylinder diameter. It is found that in practice the best cylinder ratio varies with the pressure. The reason for this may be easily seen by working out two cases, one for, say, 120 lb., and the other for, say, 90 lb. per square inch, either graphically or in the manner explained above.

The following process will show approximately the best cylinder ratio for any pressure. Take a line A B, fig. 27, 15 in. long, and B C, at right angles, 5 in. long. Join A C. Let A B represent absolute pressures to a scale of 1 in. =

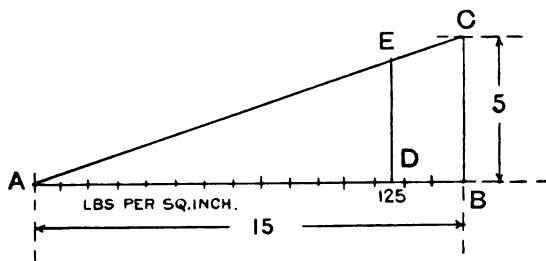

FIG. 27.

10 lb. per square inch. Then A C is the curve of cylinder ratios. For instance, suppose boiler pressure, as above, = 110 lb. above atmosphere = 125 lb. per square inch absolute. At 125 on A B erect the ordinate D E. Then the length of D E in inches gives approximately the cylinder volume ratio for that pressure. In this case it is 3.7. Hence the ratio of diameters $\sqrt{3.7} = 1.92$, since the stroke is the same in each cylinder, whence the diameter of the H.P. cylinder is

$$\frac{12.5}{1.92} = 6.5, \text{ about.}$$

Hence we have the provisional size of the engine, $6\frac{1}{2}$ in. and $12\frac{1}{2}$ in. by 10 in., with a cut-off in the H.P. cylinder of $\frac{3.7}{12}$ or about $\frac{1}{3}$ stroke. These values, however, are only provisional, and must be tried over by means of a more accurate diagram.

Before this latter can be understood we must examine more closely the action of the intermediate pipes and receiver.

Returning to the diagrammatic engine of fig. 25, and its indicator cards in fig. 26, we see that there is no intermediate

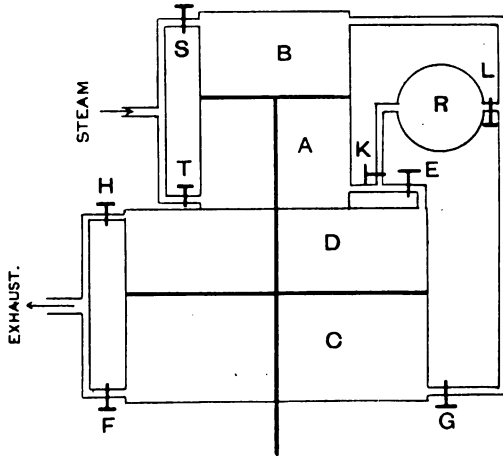

FIG. 28.

clearance, and that the intermediate valve is left open till the end of the down stroke of the H.P. piston, after which the expansion goes on in the L.P. cylinder. But in a tandem engine both pistons are rigidly connected together, and the H.P. piston reaches the end of its stroke at the same time as the L.P. piston does.

Consider fig. 28, which is a diagrammatic representation of a tandem compound engine. The valves and connections are clearly shown in the figure, and need not be further explained. The pipes are supposed to have no appreciable volume, and the engine is to work so slowly that no appreciable wire-drawing takes place. Suppose both pistons after an upstroke of the engine are in their highest positions; A is filled with partly expanded and C with completely expanded steam, K and L being shut.

(i.) *Down Stroke.*—Open valve S for one-third of the stroke, say, and E and F for the whole stroke. The result is that the spent steam in C goes to the condenser, and the steam in A expands into D. The pistons are thus forced down by the joint action of the live steam in B, and the excess of the total pressure on the large L.P. piston over that on the small H.P. piston, the pressure per square inch being the same on both pistons. During the whole of the down stroke there is a continuous fall of pressure in A and D.

(ii.) *Return Stroke.*—Close E and F, and open T for one-third stroke; open G and H for the whole stroke. The upstroke is then precisely similar to the previous down stroke, and at the end of this stroke the engine is precisely in the assumed initial condition. The indicator cards that would have been produced in this process are as shown in fig. 29, where the H.P. card is, as before, reduced to the same scale of volumes as the L.P. card. It must be noticed that the H.P. card is taken during operation (i.) from the side B of the H.P. piston, while the L.P. card is taken during operation (ii.) from the side C of the L.P. piston. This should never be forgotten in combining indicator cards from a tandem engine. The line EF is produced at the same time as the line CD. The actual shape of the L.P. card, as taken from the engine, would be E'DHG, and EFGD is produced by "reflecting" the dotted curve.

Now, mechanically speaking, such a method of working the engine as this would do very well, as it provides

perfectly for the continuous expansion of the steam, and therefore, neglecting condensation and other practical effects, we get as much work out of the steam per stroke as we could with any compound engine; but it must be noticed that in the H.P. cylinder the range of pressures is from O A to O D, with a correspondingly large range of temperatures. We should therefore in this engine lose one of the principal thermal advantages of a compound over a simple engine, viz., reduction of temperature range. Again, if the connecting passages are to be of no appreciable volume compared

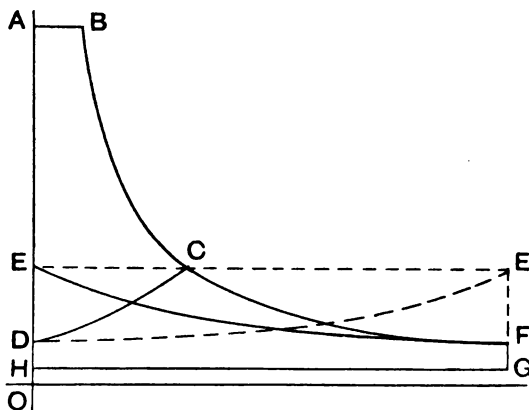

FIG. 29.

to the cylinder, they must be of very small diameter, which means that the engine will work very slowly, and therefore the weight (and, in consequence, the cost) of the engine per horse power developed will be very high. Now, in order to remedy these defects, we must—(i.) prevent the pressure in the H.P. cylinder from falling so far; (ii.) put in larger pipes, which means practically the introduction of an intermediate receiver between the cylinders. We will therefore consider the effect of introducing an intermediate receiver R (fig. 28). The valves in a compound engine are

almost always so arranged that a single intermediate pipe supplies both ends of the L.P. cylinder, and therefore we use one receiver R connected to both our diagrammatic passages.

It has been shown that the effect of opening connection from the H.P. cylinder to the receiver is to produce an immediate drop of pressure. A construction will now be explained for finding the amount of this drop, on the assumption stated in the last article. Suppose the co-ordinates of P—viz., AB, BP, fig. 30—represent, as usual, the volume and pressure of steam in the H.P. cylinder

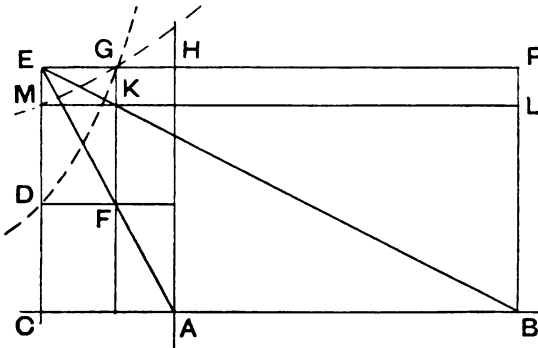

FIG. 30.

when the valve is opened. Set off AC to represent the calculated volume of the receiver—which in the case of a tandem compound = volume of exhaust passages of H.P. cylinder + volume of pipe + volume of L.P. valve chest - volume of L.P. valves—and CD to represent its pressure, which we shall at present assume known. Draw PE, DF horizontal, join AE, and draw FG vertical. Then HG represents what the volume of steam in the receiver would be if it were compressed along the hyperbola DG to the same pressure as that in the H.P. cylinder. If, then, the volume GP (which is the total volume of the

steam in the H.P. cylinder and receiver at pressure BP) be expanded to volume EP hyperbolically, the resulting pressure will be the final pressure in the receiver; therefore, join EB, cutting FG in K. M then is a point on the hyperbola MG, which has CB, BP as asymptotes. GK or PL then represents the required fall of pressure. This construction will be used in the diagram to be shortly explained. It is clear that, by keeping CD as great as possible, we shall diminish this drop, and the method for doing this, and therefore for diminishing the range of temperatures in the H.P. cylinder, is to prevent the L.P. cylinder from drawing off such a large volume of steam every stroke from the receiver—*i.e.*, cut off early in the L.P. cylinder. Observe that this does not alter the *weight* of steam drawn off by the L.P. cylinder. Any steam that enters the H.P. cylinder must of necessity pass the L.P. cylinder, because it cannot get away by any other passage. For assume that the engine is working uniformly—*i.e.*, every stroke is precisely similar to the previous one. Suppose that, if possible, say 0.25 lb. of steam leaves the H.P. every stroke, while only 0.2 lb. enters the L.P. during the same period. The result of every stroke is, therefore, that 0.05 lb. of steam is added to the quantity already in the receiver. The receiver pressure must therefore continually increase, which is contrary to our assumption that each stroke is similar to the last. In practice it is obvious that such an increase of the receiver pressure would really mean that the L.P. cylinder would draw off a greater *weight* of steam from the receiver as the pressure increased, though the volume remained the same. We have here, therefore, all the elements of an automatic pressure-governing arrangement—*i.e.*, the mean receiver pressure will continually increase till the L.P. cylinder, with a fixed cut-off, draws off exactly as much steam each stroke as the H.P. cylinder puts into it, which is, of course, by similar reasoning, exactly the quantity which the H.P. cylinder receives at each stroke from the

boiler, neglecting the effect of condensation. Hence we see that the effect of an earlier cut-off in the L.P. cylinder is not to alter either the total theoretical power of the engine or the quantity of steam that it takes (for this is simply dependent on the boiler pressure and the cut-off in the H.P. cylinder), but merely to effect a re-distribution of the power developed in the respective cylinders. A late cut-off in the L.P. cylinder causes a low receiver pressure and the development of a relatively large power in the H.P. cylinder, because it diminishes the back pressure in that cylinder; and an early cut-off in the L.P. cylinder causes a high receiver pressure, and (strange though it may seem) an increase in the power developed in the L.P. cylinder itself. This may easily be seen by considering the change in the value of the expression $p v (1 + \log_e r)$, as p increases while $p v$ is constant (since the weight of steam per stroke is unchanged). It is evident that r must increase, because the ratio of initial to final pressure increases, and therefore the value of the whole expression increases. For this reason the L.P. cylinder should be provided with a variable cut-off gear, to allow the pressure in the receiver, and in consequence the drop of pressure between the cylinders, to be adjusted. The working of the engine is still further complicated by the existence of clearance in the cylinders themselves, and the effect of this clearance is by no means to be neglected. It may be taken into account by remembering that when steam expands in any space the whole of that space must be taken into account. A convenient construction allowing for all clearances will be shortly explained.

Neglecting cylinder clearance for the present, the working of our diagrammatic engine under the new conditions would be as follows:—

- (i.) Open S for one-third of the down stroke, then close it till end of stroke.
- (ii.) Open K, producing a drop of pressure in A.

(iii.) Open E for, say, two-fifths of the stroke.

(iv.) Then close it.

(v.) Open F for the whole stroke.

The result of (iv.) is that the steam then in A and R is compressed in the receiver, and in the diminishing volume A by the advancing H.P. piston, in such a way that the

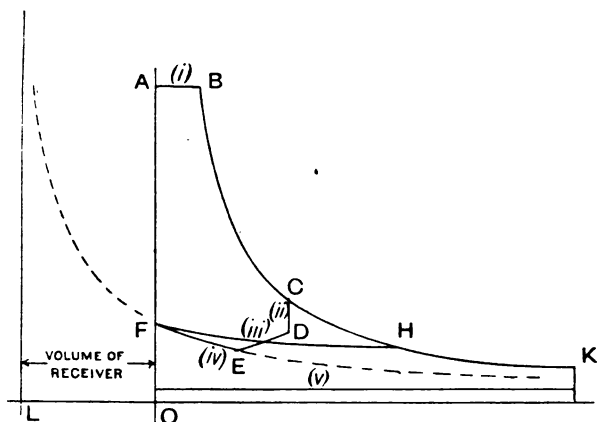

FIG. 31.

common pressure in A and R at any instant \times the total volume at the same instant is constant.

Perform the same series of operations with the corresponding valves for the return stroke.

The cards that would be produced by these processes are shown in fig. 31. The dotted lines show the hyperbolas of which the lines in the cards are part.

FH and DE are described at the same time, and EF is part of an hyperbola, with $L'M$, LN as asymptotes.

CHAPTER V.

COMPOUND DIAGRAMS.

WE now proceed to draw a set of indicator diagrams for our proposed tandem compound engine, which, according to the assumptions previously noted, will be an accurate one, and which do, in fact, represent with fair accuracy the actual diagrams which the engine may be expected to produce, allowance having been made for a moderate amount of wire-drawing.

Before doing this, however, we must draw in the cylinders in outline, so as to be able to determine the volumes of the various parts constituting the clearances. It is very undesirable to draw in more of the design at this stage than is necessary for the object in view, because the sizes may have to be modified according to the information derived from the diagram. The necessary areas of the steam and exhaust ports have been already found. Care must be taken especially that the area of the exhaust is not in any way constricted. Insufficient area of exhaust is a very bad fault in an engine, and it is one which is very liable to occur, because the exhaust port of an engine is of a peculiar shape, and the ordinary three sections which are usually given in a working drawing are apt to mislead the unwary draughtsman into the belief that the area is unrestricted, when, in fact, it is not so. The core boxes for the ports are often so made that plates between the steam and exhaust ports are curved, following the curve of the cylinder, fig. 32. The shape of these plates is often not shown on a working drawing, and the pattern-maker is left to make them what shape he pleases. If he decides to make them cylindrical in section, it may happen that the plate projects over part of the area of the exhaust pipe where it joins the valve chest,

thus constricting the exhaust.* In a case which recently came under the author's notice, the exhaust area in a large engine was constricted at this part to the extent of nearly 25 per cent, as shown in fig. 32, at E. In some cases also the valve is made so shallow that there is insufficient area over the top of the bar, as at C D. In some cases also the valve

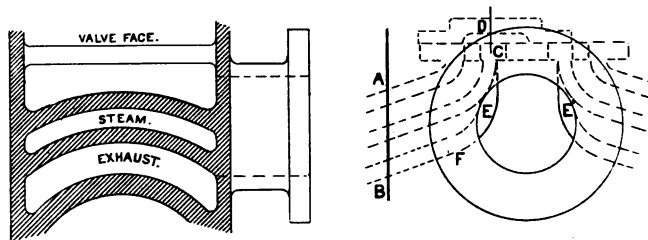

Section on A B.

FIG. 32.

face is so near the cylinder that the escaping steam from one-half of the exhaust port is throttled on its way to the exhaust pipe.

The distance piece between the cylinders should be great enough to allow plenty of room for the stuffing boxes to be packed. When this distance has been determined, we can find the necessary length of connecting pipe. The calculation for its sectional area is complicated by the fact that in the pipe expansion and flow of steam are going on simultaneously. If we calculate the section of the pipe considered as the exhaust pipe of the H.P. cylinder, the

* Care must be taken that the plates are of such a shape that there are no triangular lumps of metal at the points where the plates between the steam and exhaust ports join the cylinder, as will be the case if the angle of junction is very oblique. This is a fruitful cause of spongy castings. The sponginess occurs at a place where it is difficult to detect it, and may produce a tremendous waste of steam, the cause of which may afterwards be very obscure to anyone who has not seen the design. For this reason the plates should join the cylinder as directly as possible. The edge of the exhaust core will then be substantial, and not likely to be broken off by the flow of metal during casting.

result will, of course, be quite different from that derived from the assumption that it is the steam pipe of the L.P. cylinder. It is clear that neither of these is the correct assumption, because the pressure of steam during admission to the L.P. cylinder is not maintained constant by the supply it receives from the pipe, but is continually falling during that period. The steam already in the L.P. cylinder is expanding, as well as that in the H.P. cylinder and pipe, and, therefore, the volume of steam supplied per second by the pipe is not so great as the volume swept out per second by the L.P. piston. In addition, steam is being driven into the pipe by the advancing H.P. piston. The velocity of steam in the pipe will be greatest at the point where it joins the L.P. valve chest, because here the integral effect of the steam displaced by the H.P. piston and the expansion in the H.P. cylinder and pipe is felt. The exact point of the stroke at which the velocity of the incoming steam is a maximum can only be determined for each particular case by the use of the differential calculus. In several cases calculated by the author, the result was nearly three-eighths of the stroke. In any case it cannot be far from this point. At this point of the stroke, and at this section of the pipe, the velocity must not be greater in ordinary cases than 80 ft. per second. In high-speed engines anything less than 110 ft. per second gives an abnormally large pipe. The method of calculating the actual velocity at this point may be best understood by imagining that the cylinders and cylinder clearances are replaced by equal volumes of pipe, whose diameter is the same as that of the connecting pipe. In the pipes representing the cylinder volumes, pistons are to be imagined working whose volumetric velocities (*i.e.*, volume displaced per second) are the same as the corresponding volumetric velocities of the respective pistons, and which enclose between them the same quantity of steam as the actual pistons at three-eighths stroke. It is clear that the velocity produced in the connecting pipe in this case will be the same as in the actual case. It is also easy to see that

if the expansion goes on uniformly throughout the whole volume enclosed, so that at any instant the pressure is the same throughout the whole volume, the volumetric velocity of a diaphragm which divides this volume into two parts at the section corresponding to that described above, will be found by the following construction : Set off A B, fig. 33, to

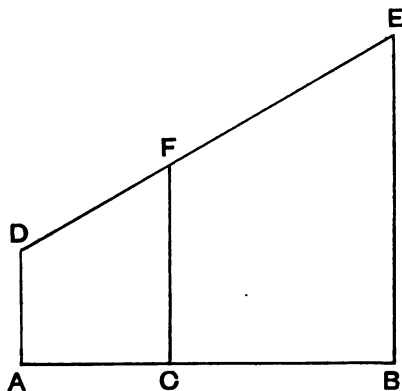

FIG. 33.

represent the whole volume between the pistons at three-eighths stroke—*i.e.* (five-eighths volume of H.P. cylinder + exhaust passage of ditto + volume of connecting pipe, which must be approximately estimated) + (volume of valve chest of L.P. cylinder + three-eighths volume of L.P. cylinder). Make A C equal to the first bracket, and C B equal to the second. Set up A D = volumetric velocity of H.P. piston in $\frac{\text{in.}^3}{\text{sec.}}$ (*i.e.*, volume of H.P. cylinder \times strokes per second), and B E = that of the L.P. cylinder. Join D E, and set up C F vertical. The length of C F gives the volumetric velocity required. Divide this by 960 in. per second, and we obtain the area required in square inches, which, when multiplied by the length already found, gives the volume of

the pipe. To find the volume of the H.P. exhaust port, the following method is useful, and, if worked with a planimeter, is very rapid, and may be worked to any desired degree of accuracy. The theory of this construction is fully explained in the author's work on a "Graphical Treatment of the Differential and Integral Calculus."

Make a scale drawing of the port, fig. 34, and take a number of sections across it, as shown in figure, and determine the sectional area of the port at each of these sections.

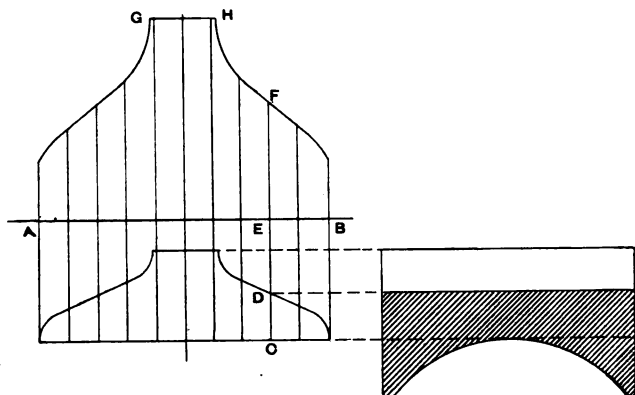

FIG. 34.

Set up these areas to scale on a convenient base AB, at corresponding points. Thus the area of the section across CD is shown shaded in the end elevation. Suppose this to be 22.3 square inches. Set up EF to represent 22.3 on any convenient scale, and do the same for all the other sections. Draw a curve AGHB through all the points so obtained. The area of this curve will be the required volume of the exhaust port. The scale to which the area represents the volume may be found by considering what a square of 1 in. side would represent on the diagram. Suppose the drawing

of the port is on a scale of 3 in. = 1 ft.—*i.e.*, 1 in. represents 4 in.—and the scale of the ordinates is 1 in. = 10 in.², then the square inch of the area represents 4 in. × 10 in.² = 40 in.³ of volume. If the area of the curve is, say, 8.23 square inches, then the required volume is 8.23 × 40 = 329.2 cubic inches. We can thus obtain accurately the intermediate volume, and we have now all we require to draw the diagram.

We shall first show how to draw diagram so as nominally to avoid any drop between the cylinders (though a small drop is usually caused by condensation and other effects, of which we cannot well take count); but it may be stated that it is generally impossible to secure this result unless some form of cut-off gear is fitted to the L.P. cylinder. This is not usually done, as it increases the first cost of the engine; but it adds considerably to the economy when it is done. Suppose we have a boiler pressure of 95 lb. per square inch, and have provisionally determined the cylinders to be 10 and 18 by 12. These may have to be subsequently modified if the diagram is not satisfactory, either because—(1) the total power is not correct; (2) the total power is not correctly divided between the cylinders.

(1) We can alter the *total* power either by—(i.) altering the cut-off in the H.P. cylinder, by which means we alter the pressures throughout the stroke; (ii.) altering the diameter of the L.P. cylinder.

(2) Now, we may also alter the proportion of the total power developed in the two cylinders in two ways: (i.) By altering the cut-off in the L.P. cylinder; (ii.) by altering the diameter of the H.P. cylinder.

Now, by varying (2) (i.) we vary the drop between the cylinders, and if it is correctly adjusted we can do away with the drop altogether. Hence the best thing to do is to adjust the total power by means of (1) (ii.), using (1) (i.) as a fine adjustment, and the relative power by means of (2) (ii.), and the drop by means of (2) (i.).

In case, however, we are limited to one valve in the L.P. cylinder, where an earlier cut-off than can be obtained with a single valve would be desirable, we must cut off as early as possible, and do the best we can under the circumstances. It will be subsequently shown how to modify the diagram to meet this case. It will generally be found that a smaller H.P. cylinder is necessary where no cut-off valve is used on the L.P. cylinder, in order that the power developed in the H.P. cylinder may not be excessive. It is impossible in practice to cut off before half-stroke when only a single valve is used; indeed, it is necessary to increase the stroke of the valve and the lap very considerably even for this cut-off, if we are to get full area for steam and avoid excessive lead, which latter makes the engine very difficult to start, and is apt to cause bad "knocking" by producing reversal of stress too early, with disastrous effect on the connecting-rod brasses.* Such an early cut-off is out of the question in many cases, owing to the small size of the valve chest, which limits the possible throw of the valve.

The following are the particulars of the engine for which we shall draw the diagram: Cylinders, 10 and 18 × 12; condensing; volumes of cylinders—H.P., 943 cubic inches, L.P., 3,050 cubic inches; boiler pressure, 90 lb. above atmosphere; clearances—H.P., 6 per cent = 56·6; L.P., 8 per cent = 244.

Volume of H.P. exhaust port...	= 198	cubic inches.
Connecting pipe	= 460	„
L.P. valve chest (less volume of valve)	= 392	„
Total inter. clearance	1,050	„

Let expansion be carried to 10 lb. per square inch absolute (i.e., total ratio of expansion equal 10), allowing for a drop

* The author knows one engine where this effect is very pronounced. The brasses are a constant source of trouble, and have a very short life.

of 5 lb. between boiler and engine. Then initial volume of steam in H.P. cylinder

$$= \frac{10}{100} \times 3294 = 329.4,$$

since, as already shown, the same weight of steam enters the H.P. cylinder every stroke as is discharged from the L.P. cylinder.

In this is included H.P. clearance = 56.6. Hence, cut-off in H.P. cylinder

$$= \frac{329.4 - 56.6}{943} = \frac{272.8}{943} = \frac{1}{3} \text{ stroke, about.}$$

For convenience of reference, and to fix our ideas, suppose the engine vertical.

We must first have a means of determining at once the total volume contained at any part of the stroke between the H.P. and L.P. pistons. The easiest way to do this is as follows:—

Set off A B, fig. 35, equal to the intermediate clearance, as above defined.

A C = H.P. clearance.

B D = L.P. clearance.

C E = working volume of H.P. cylinder.

D F = working volume of L.P. cylinder.

Describe the square E C G H, and complete the construction shown in figure E F J K H. From this figure we can at once find the intermediate volume at any point of either stroke—say at two-fifths of the down stroke, thus: Make C L = two-fifths C E. Draw L M vertical to cut one or other diagonal in M; then N P represents the required volume. Similarly, the volume at three-fifths of the up-stroke is represented by Q R. Only common sense is required in selecting the proper points from which to measure. Take a convenient base line O O to represent absolute zero of pressure on a convenient scale, and set up O a to represent 14.7 lb. per square inch on this scale.

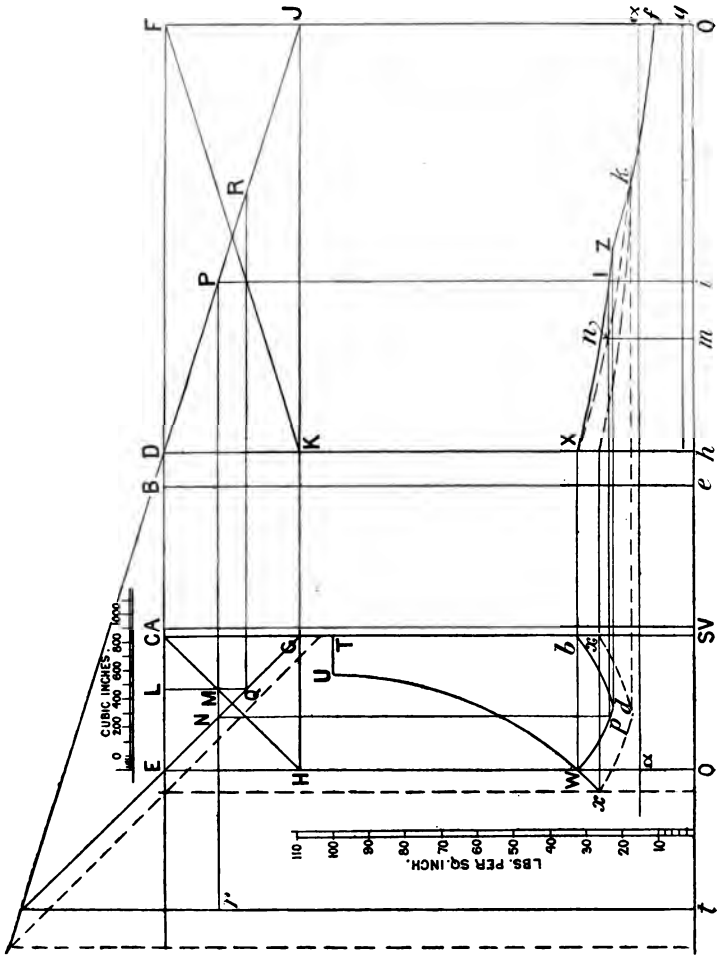

FIG. 35.

Draw aa the atmospheric line. Set up ST to represent absolute initial pressure in H.P. cylinder—*i.e.*, 5 per cent below boiler pressure = in this case about 100 lb. per square inch. Set off TU = admission volume in the H.P. cylinder = 272.8 cubic inches. U then represents the point of cut-off. Draw the hyperbola UW with VO , VA as asymptotes. The line TUW represents the top line of the H.P. card. The pressure at W will then be

$$\frac{329}{999.6} \times 100 = 32.9.$$

At the point W connection is supposed to be opened to the receiver, but as this is, by assumption, to cause no drop, it is clear that the pressure of the steam left in the receiver after the previous stroke must be the same as the pressure at W . The initial pressure in the L.P. cylinder will then be the same as at W , assuming that the exhaust in the L.P. cylinder has been cushioned at the proper point on the previous stroke. Transfer then the pressure W to X , as shown. Now, during the first part of the return stroke the product of pressure and volume of the steam in the receiver must be constant. At first the volume is Oh , and the pressure hX . Hence, if we draw an hyperbola (dotted) through X ,* with OO , OE as asymptotes, this line will show the corresponding values of pressure and volume, the volume at any point of the stroke being taken from the figure at the top of the diagram, and the corresponding pressure being found by setting off the volume along OO , as at Om (which = NP), and finding the corresponding pressure, mn . Ip are then points on the curves. A number of these points may be determined, and the curves Wd , XZ drawn through them. If the paper is big enough, we may get these curves more directly; for, since the curve XZ is such that any ordinate such as $iI \times NP$ is constant, and since NP is proportional to rP , it follows that $rP \times iI = \text{constant}$;

* This line is not, of course, the admission line for the L.P. cylinder, but merely a curve for reference.

whence the curve XZ is an hyperbola, with tr , rO as asymptotes where the line rt is obtained in the manner shown in the diagram. The hyperbola Wd may also be drawn with the same asymptotes, since rN is proportional to NP , or Wd may be projected from the other curve. Now comes the question where this part of the curve must be stopped—that is to say, where cut-off takes place in the L.P. cylinder. This we shall decide by considering the state in which the steam in the receiver is to be left in readiness for the next stroke. The pressure at which it must be left is clearly the pressure of W . After the L.P. steam port has closed, the advance of the H.P. piston compresses the remaining steam into the receiver, and therefore, since b must be a point on the compression curve, it is clear that the remaining portion of the H.P. card must be an hyperbola through b , with eB , eO as asymptotes, cutting the other curve in d . Hence dZ are the corresponding points at which the L.P. valve must cut off steam.

The L.P. card can now be completed by drawing through Z the hyperbola Zf , with eB , eO as asymptotes, and drawing the back-pressure line horizontal.

This construction shows both cards as entirely made up of hyperbolas, as follows:—

Portion of card.	Asymptotes.
TU	OO and line at infinity.
UW	OO and VA .
Wd	OO and tr .
db	OO and eB .
XZ	OO and tr .
Zf	OO and eB .
gs	OO and line at infinity.

The cards may be very rapidly drawn if this is borne in mind.

Next find the area of each of these curves.

(1) Add them together, and compare with the power required. For safety, this sum should be at least 10 per cent in excess of the requisite power, after allowing for mechanical efficiency.

(2) If there is any considerable difference in the areas, proceed as before explained to alter the volume of the H.P. cylinder.

The approximate amount of alteration can be estimated by drawing a few continuations of these diagrams, as shown. The figure shows how to do this in the case when the H.P. card is too small.* The curves must be modified in this way till they are approximately equal. The volume $x x$ of the H.P. cylinder can then easily be found by measurement, and its diameter calculated.

From the diagram, fig. 35, given on page 75, it is easy to see what effect the size of the intermediate receiver has on the indicator cards. If we increase the length of AB , we clearly (i.) cause the hyperbola db to rise less rapidly towards the right, or, in other words, to fall less rapidly towards the left. This tends to move the point d , and therefore also the point Z , towards the left, which tends to make the cut-off earlier in the L.P. cylinder; (ii.) on the other hand, we cause the line tr to move towards the left, thereby causing Wd to fall less rapidly towards the right, which has an opposite effect on the point Z . Of these two contrary variations, (i) will be found, and may easily be proved, to have the greater effect. The net result is, therefore, that the larger the receiver the earlier will be the cut-off, and *vice versa*. When the receiver is very large, the L.P. cut-off will be nearly the ratio of the cylinders, and when there is no receiver cut-off occurs at the end of the L.P. stroke. The

* The whole of the actual construction is not shown in fig. 35, for want of space, and to avoid confusion of the figure. Another complete rectangle would have to be drawn, and other diagonals of the L.P. rectangle, which would throw the dotted vertical line further to the left. Enough is, however, given to show the method of procedure.

effect of increasing the receiver is also to diminish the range of pressures in the receiver, which secures a thermal advantage. When the receiver is infinitely large, there is no variation of pressure in it, and the cards are then precisely the same as in the case of the ideal engine first described, pp. 50—52, fig. 26, the back pressure in the H.P. cylinder and the admission pressure in the L.P. cylinder being constant and equal. Now, as we are usually, in a tandem engine, limited to a single ordinary slide valve, it becomes necessary to find the earliest practicable cut-off in the L.P. cylinder. This is usually somewhere between $\frac{1}{2}$ and $\frac{2}{3}$ stroke. We have then to determine the suitable volume of receiver. If the engine is not a quick-running one, it is sometimes possible to make the receiver of the size found by this construction, but if the engine is a high-speed one, it is usually impossible to get it small enough, owing to the large size of the connecting pipe and passages. Care must be taken in designing the L.P. valve chest that the steam has free access from the connecting pipe to the remote port of the valve face. One frequently meets with designs in which the L.P. valve either partly closes up the admission pipe at one end of its stroke, or so fills up the valve chest that there is not sufficient area between the valve and valve-chest cover for the steam to get free access to the port remote from the steam pipe. Sometimes both of these faults exist in the same engine. In many cases it is necessary that the admission pipe should join the valve chest in an ellipse—i.e., merge from a circle at the flange into an ellipse, in order not to be partly covered by the valve. Assume any arbitrary distance for A B (on which we shall have to find the actual position of B), and make the same construction as before as far as the point W in the H.P. card.

When the earliest practical cut-off in the L.P. cylinder has been found and marked off by a vertical line on the assumed L.P. card, the final pressure in the L.P. cylinder must be calculated, and the point *f* must be marked off to correspond, and the hyperbola *Zf* drawn backwards to cut this vertical.

This gives the pressure at cut-off. Find the corresponding point d on the H.P. card by the intersection of a horizontal through Z and the vertical which marks the position of the H.P. piston, when the L.P. piston is at Z . We have then two points, W and d , on an hyperbola, and one of its asymptotes, OO , given, and are required to find the other asymptote, tr . Make a horizontal rectangle with Wd , at two of its corners. The point where the line joining its other two corners cuts OO will be on the other asymptote tr , which can then be drawn and the point where it cuts GE found. Through this point draw a line parallel to the diagonal DJ of the L.P. rectangle. The actual position of the point D on the line AB is thus found, from which we have the volume AB of the intermediate clearance required to correspond with the given cut-off in the L.P. cylinder. As has been already said, this will usually result in a clearance smaller than can be obtained with a quick-running engine of the ordinary type. If so, keep the clearance as small as possible, and find the line tr . Draw the hyperbola ZX backwards, and the difference in height between the point where the hyperbola UW cuts OE and X will give the drop in pressure much more simply than it can be obtained by the long row of simultaneous equations usually given for this purpose. The curve db can also be drawn as before, showing the receiver pressure just before H.P. release.

The point of compression in the L.P. cylinder can be found (so as to leave the steam on the L.P. clearance at the beginning of the stroke at the same pressure as that in the receiver) by drawing an hyperbola through X , with asymptotes eB , eO , to cut the back-pressure line. Thus the inside lap of the L.P. valve can be determined from the elliptical diagram already drawn. But it must be observed that a great amount of compression makes the engine very difficult to start, and if the engine is a large one, and has to be frequently stopped, this is a very serious drawback unless some special form of starting gear is supplied in addition. It is better, therefore, not to compress quite so early as this

unless the engine is small and the pressure and the speed both high, in which case starting is usually a very easy matter, though the engine has always to be "barred round" into a starting position—i.e., well over dead centres.

Cranks Opposite.—The principle of the above diagram is easily applied to the case of cranks opposite, which is a favourite form for high-speed engines which have to be carefully balanced. The reason for this will be discussed in a future chapter. There is this difference between a tandem-engine diagram and that of an engine with cranks opposite, that in the latter the lines DJ, FK are not straight, owing to the effect of obliquity, but must be found by the following construction. Also the steam from the top of the H.P. cylinder expands into the top of the L.P., and that from the bottom of the H.P. into the bottom of the L.P.

The lines DJ, FK are obtained as follows: Draw two concentric circles, fig. 36, whose diameters are, if possible, equal to, but in any case some simple sub-multiple of the

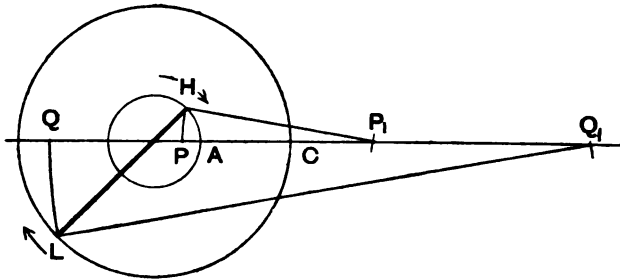

FIG. 36.

lines EC, DF. Let these represent, to different scales, the paths of the respective crank pins. Take the lengths of the corresponding connecting rods HP_1 , LQ_1 respectively to the same scales as their crank circles are drawn. Take a number of corresponding positions (such as HL) of the two pins, and by a construction similar to that explained in Chapter II. find the positions of the pistons in the cylinders.

Then it is clear that the lengths AP , CQ give the volumes of the steam in the respective cylinders. To find the points on the diagram corresponding to the positions shown on fig. 37, take a point N , fig. 37, on the straight diagonal CH , such that $NM = AP$, fig. 36, the rest of the construction being precisely as in fig. 35. Make $IR = CQ$. Then R is a point on the curve FK , and the length NR will, as before,

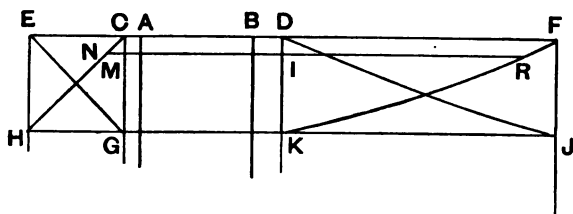

FIG. 37.

represent the volume between the pistons at this particular point of the stroke. Other points may be found in the same way, and the curves DJ , FK drawn through them. Care must be taken that the corresponding volumes considered are the volume behind the H.P. piston (*i.e.*, on the exhaust side of), and in front (*i.e.*, on the admission side) of the L.P. Take one pair of diagonals EG , DJ for the downstroke, and the other pair for the upstroke.

It is clear that the curves Wd , XZ , of fig. 35, will not now be hyperbolas, but points on them must be found by calculation, as follows: At the moment of release the volume is represented by ED , fig. 35, and the pressure by OW . Now, the curve Wd must be such that, at any point p on it, the volume $NP \times$ the pressure mn is equal to the product of ED and OW . It will easily be seen that it is unnecessary to trouble about the scale of volumes and pressures to get this curve. Measure ED , OW in inches, and multiply the lengths together on the slide rule, and divide by the length of NP . This gives the actual height on the diagram of the points p and I above OO ; other points

on the curve can be similarly calculated, and the whole curve drawn. The line db is, of course, drawn as before.

Cranks at Right Angles.—Exactly similar principles govern the drawing of diagrams for cranks at right angles, but this diagram is somewhat confusing, owing to the peculiar relative motion of the pistons. This motion must be found by a construction similar to that of fig. 36. Suppose that, as usual, the H.P. crank leads. Draw two straight diagonals, as before, across the H.P. rectangle, and find by construction, as at fig. 39, the positions of the L.P. piston corresponding to several points on these diagonals. Plot the volumes off, as before, in the L.P. rectangle, taking great care that the L.P. volume so represented is the volume of steam driving the L.P. piston corresponding to the assumed position of the H.P. piston. Thus on the upstroke of both pistons (the H.P., of course, leading), at the point L , the exhaust volume in the H.P. cylinder is MN , and the volume of the steam driving the piston in the L.P. cylinder is QP . This is the point corresponding to the positions shown at fig. 39. The curves of position of the L.P. piston will then be distorted elliptical figures, as shown in the diagram.

When these have been drawn and labelled upstroke or downstroke, as the case may be, draw the H.P. admission and expansion curves. Consider the downstroke of the H.P. piston. At the end of this stroke at W the L.P. piston is about half way on its downstroke at R , and is not in a position to receive steam. Connection is opened from the top of the H.P. cylinder to the receiver, the pressure in which at this point is to be the same as that in the H.P. cylinder at the end of the stroke. Hence the first part of the return stroke of the H.P. piston compresses the steam into the receiver, and the indicator describes the curve Wp , which is an hyperbola with OO , eB as asymptotes. The larger the receiver the less the rise of pressure, and since excessive changes of pressure in the receiver are undesirable on account of the tendency to wet the steam supplying the L.P. cylinder, it is customary to fix the minimum volume of

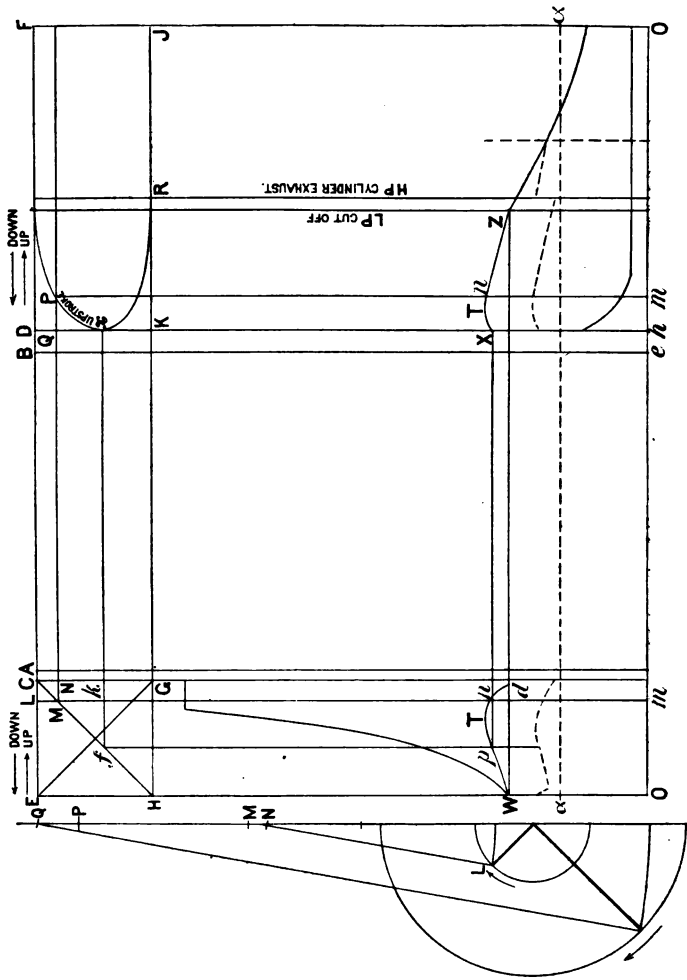

FIG. 88.

FIG. 39.

receiver as the volume of the L.P. cylinder. At about half stroke of the H.P. cylinder the L.P. valve admits steam to the L.P. cylinder, but at this point and for a short time afterwards, the volumetric velocity of the H.P. piston being greater than that of the L.P. piston, the pressure in the receiver continues to rise, though more and more gradually, as the volumetric velocity of the L.P. piston increases. The line of pressures becomes parallel to OO at the point T , where the volumetric velocities of the two pistons are equal, after which it commences to fall. Points on the curve must be calculated exactly as explained above, the volumes being measured off from between the H.P. diagonal and the corresponding L.P. ellipse at the top of the figure, as at MP .

The L.P. valve opens to the receiver at the point X , at which time the exhaust volume on the H.P. cylinder is fk . Hence the total volume of steam about to expand is at this instant fx , which length measured in inches, multiplied by the length hX , gives the equivalent of the product of such corresponding pairs of lines as MP , mn . Cut-off should take place in the L.P. cylinder at the point dZ , where the line of pressures has fallen to the same height as the point W . The pressure in the receiver is then left the same as the final pressure in the H.P. cylinder, thus avoiding drop in the succeeding strokes. Cut-off should always, where possible, take place in the L.P. cylinder before the other end of the H.P. cylinder exhausts, otherwise it is impossible to prevent drop of pressure, as it always is when there is only one ordinary slide valve driven by an eccentric for the L.P. cylinder. In this case there will be a sudden rise of pressure in the L.P. cylinder near half stroke, as shown in dotted lines in the figure. It is therefore always desirable to have a variable cut-off gear for the L.P. cylinder, though it is not usually done on account of first cost. It is desirable to draw two such diagrams, one for each end of the cylinders. The points of cut-off, &c., having now been fully determined, the valves can be accurately designed in accordance with foregoing principles.

In fig. 38 it is evident that the work done in the L.P. cylinder is considerably greater than that done in the H.P. cylinder. In this case, therefore, it is evident that the H.P. cylinder must be considerably increased in volume. A high boiler pressure necessitates a high rate of expansion in the H.P. cylinder, in order that equality may be established between the work done in either cylinder. Many authorities assert that a higher rate of expansion than 3 cannot be advantageously conducted in one cylinder, which, of course, would limit seriously the use of compound engines as against triple-expansion for pressures above about 75.

The principles here explained can be easily applied to the case of triple-expansion engines, which therefore needs no further explanation.

CHAPTER VI.

FLYWHEELS.

AN engine flywheel is in reality a governor which prevents rapid fluctuations of speed in an engine. Its function is to limit the amount of variation of speed which would take place in one revolution, owing to the fact that an engine cylinder with piston and connecting rod does not furnish a uniform supply of power during one revolution. For instance, at the moments when the engine is passing dead centres the steam is doing no work at all, since the piston is at rest at these points, while at some other parts of the stroke the rate of doing work is much greater than the mean. When a flywheel is running at a certain velocity V_1 , it contains a certain definite number of foot-pounds of work, which can be easily calculated. If its speed is altered to V_2 by the action of any accelerating or retarding force, the amount of work it contains increases or diminishes, as the case may be, and the amount of work it absorbs or gives

up in this process is the difference in the amounts of work it contains when running at V_1 and V_2 respectively. It is imperative that the designer should know how to calculate the amount of work stored up in the flywheel. This is explained in every book on elementary mechanics. It is as follows:—

Let M be the weight of the rim in pounds ;

V its velocity in feet per second ;

g the acceleration due to gravity = $32 \frac{\text{ft.}}{\text{sec.}^2}$;

number of foot-pounds = $\frac{M \times V^2}{2g}$.

Of course, no flywheel can limit the rate of speed at which an engine runs. The most it can do is to limit the rate at which the variations take place—*i.e.*, to prevent the engine from changing from a slow speed to a high one, or *vice versa*, too rapidly. The heavier the flywheel, the longer time will such a change require.

To estimate the weight of flywheel required there are, as usual, a rough approximate method, and a more or less accurate one. The former is used in cases where no special uniformity is required, and the latter where a definite degree of uniformity is specified.

1. *Approximate Method.*—According to this method the flywheel must be of such a size and weight that when running at the normal speed it contains an amount of work equal to some definite multiple of (usually $3\frac{1}{2}$ times) that developed in the cylinders during one revolution.* The following is a specimen of this kind of calculation:—

H.P. = 12 ; revolutions per minute = 250 ;

therefore work done in one revolution

$$= \frac{12 \times 33000}{250} = 1584 \text{ foot-pounds.}$$

We have first to guess at a suitable diameter for the wheel. The larger the wheel, the lighter may we make the rim, and

* In very slow running engines half this amount of energy is usually considered sufficient, otherwise the flywheel weight would be very large.

the weaker will it be. The draughtsman must rely on his eye to tell him when he has got a wheel of good proportions. It is usual to limit the velocity of a flywheel rim to a mile a minute, or 88 ft. per second at the outside; for, although the tendency to burst the wheel does not depend solely on its velocity, it is found that the rim must be of unusual proportions if it is to run beyond this speed with safety. In making this preliminary estimate, we must be guided by experience. In this case since the speed is moderately high, and the power small, a small wheel will suffice, say, mean diameter, 2 ft. 6 in.

$$\text{Velocity of rim in } \left(\frac{\text{ft.}}{\text{sec.}} \right) = \frac{2.5 \times \pi \times 250}{60} = 32.6 \frac{\text{ft.}}{\text{sec.}}$$

Let x pounds be its weight.

Its energy according to above rule is

$$\frac{x \times (32.6)^2}{2 \times 32} = 16.6 x \text{ foot-pounds.}$$

Hence, since this energy must be $3\frac{1}{2}$ times that developed in one revolution, we have

$$16.6 x = 3.5 \times 1584;$$

$$x = \frac{3.5 \times 1584}{16.6} = 335 \text{ lb.};$$

$$\text{volume of rim therefore} = \frac{335}{0.26} = 1290 \text{ cubic inches,}$$

since 1 cubic inch of iron weighs 0.26 lb.

Now, the mean length of circumference of the flywheel rim is $30 \times \pi = 94$ in. Sectional area is, therefore,

$$\frac{1290}{94} = 13.8 \text{ square inches};$$

or, say $4\frac{1}{2} \times 3\frac{1}{2}$.

The arms and boss of the wheel are here not taken into account. They may be looked upon as furnishing a margin in favour of uniformity. In most engine shops a number of flywheel patterns are already in existence, and the

draughtsman has to select from these the one most suitable for his purpose, that is generally the next one larger than his calculated size.

In some cases where uniformity of speed is not of consequence, much smaller wheels may be used (with a consequent saving of expense) especially as there are usually a number of rotating wheels, &c., driven by the engine which themselves act as flywheels. In every case the flywheel should contain at least as much energy as is developed in the cylinders in one revolution.

2. *Accurate Method.*—This method does not depend on any empirical rule as the last does. It is to be used when a specified degree of uniformity has to be attained during one revolution. Thus it is often specified that the maximum variation of speed is to be not greater than $2\frac{1}{2}$ per cent above or below the mean. Perhaps the best process to adopt in these cases is to compare, by means of curves, the twisting moment necessary to keep the engine running while performing its work (this is usually taken as constant) with that produced by the action of the steam on the piston (which varies continuously) at each point of revolution. It is then easy to find (as will be presently explained) the amount of work which must be done by the flywheel in that part of the revolution during which the work done by the steam on the piston is less than that drawn off from the engine by the work that is being done. The flywheel must then be of such a weight that it can supply this defect of work without its velocity being reduced by more than the specified variation. In making this calculation, we may, if we please, include in the calculation the arms and boss of the flywheel. They are, however, of small effect compared to the rim of the wheel, and are generally neglected since any error they produce is in favour of uniformity. We shall, in a later chapter, show how the inertia of the moving parts affects the question.

Having given this *résumé* of what we are about to do, we shall proceed to draw the curve of twisting moment due to

the pressure of steam on the piston, treating this pressure at first as uniform, subsequently showing how it may be modified to suit any proposed indicator cards. Instead of finding the twisting moment directly in pounds-inches, we shall find, at all points of the revolution, the magnitude of a force, which, acting on the crank pin at right angles to the crank, will produce the same twisting moment on the shaft as the actual force along the connecting rod does. As far as work done and driving force are concerned, we may replace the piston and connecting rod by this imaginary force. The

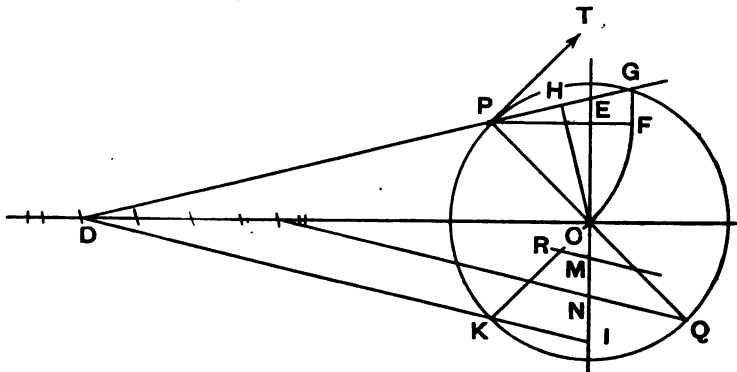

FIG. 40.

other component of the force due to these parts only produces stress in the engine and has no effect on the driving force.

To find the actual magnitude of this imaginary force T at any point of the stroke such as P , fig. 40.

Find the total force on the piston, say 2,760 lb.

Determine what scale of forces we are to use, suppose we say 1 in. = 1000 lb.

Describe a circle centre C , whose radius represents on this scale the force on the piston. In this case the radius of the circle will be 2.76 in. Let this circle represent, also to scale,

the path of the crank pin, so that 2.76 in. also represents the crank radius = 5 in., suppose. The length scale is then $1 \text{ in.} = \frac{5}{2.76} = 1.8 \text{ in.}$ Find the length of the connecting rod to this scale.

If the rod is, say, five cranks long, its length will on this scale be 13.8 in. Take P D, as usual, = 13.8 in., and produce D P to E, if necessary. If P is taken on the other side of the vertical, as at Q, this will not be necessary. The construction and proof are exactly the same wherever P is taken. Then, we shall show that C E to our scale of forces is the value of the tangential force P T. In the case of the point Q, C N is the value required. First, describe the circle C F, as shown, draw P F horizontal and F G vertical and C H perpendicular to D G. Now, the triangle P F G is the triangle of forces acting on the crosshead pin (see any book on elementary mechanics), and since P F = P C = force on piston, P G represents the force in the connecting rod and F G the upward force due to the pressure of the slide bar.

Now, the twisting moment due to the force P G is P G \times C H. The actual value would be obtained by finding the actual length represented by C H (by multiplying the length of C H by the scale of lengths), and the actual value of the force P G (by multiplying its length in inches by the scale of forces), and multiplying the two together, thus—

$$\begin{aligned} \text{Twisting moment} &= P G \times C H \times \text{scale of lengths} \times \text{scale} \\ &\quad \text{of forces.} \\ &= P G \times C H \times 1.8 \text{ in.} \times 1000 \text{ lb.} \end{aligned}$$

Now, the twisting moment due to a force C E acting at P tangentially is in just the same way—

$$\begin{aligned} &C E \times P C \times 1.8 \text{ in.} \times 1000 \text{ lb.} \\ &= C E \times P F \times 1.8 \text{ in.} \times 1000 \text{ lb.;} \end{aligned}$$

and what we have to prove therefore amounts to this:—

$$\begin{aligned} P G \times O H \times 1.8 \text{ in.} \times 1000 \text{ lb.} &= C E \times P F \times 1.8 \text{ in.} \times 1000 \text{ lb.} \\ \text{i.e., } P G \times C H &= C E \times P F. \end{aligned}$$

Now, the triangles GPF , ECH are similar, since all the angles of each are equal (for one angle of each is a right angle, and $HEC = PGF$); therefore

$$\frac{PG}{PF} = \frac{CE}{CH}$$

Therefore $PG \times CH = CE \times PF$, which was to be proved. We can therefore find in the same way the total couple turning the engine at every point of the stroke. But this variable force acts along a circular path—the crank-pin circle—and if we plot its value at each point on the crank-pin circle unrolled, the area of the curve thus produced will give the amount of work done in foot-pounds, just as the area of the indicator card gives the amount of work

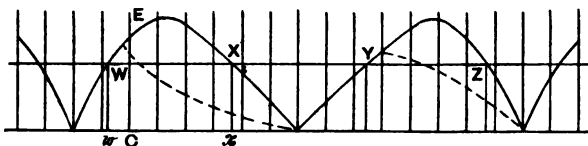

FIG. 41.

done (see any book on mechanics). This is the curve we are about to draw.

First calculate the actual circumference of the crank-pin circle. In this case it is $5 \times 2\pi = 31.42$ in. Select a convenient scale, say, $\frac{1}{2}$ full size (we need not adhere to the original scale of lengths), and set off a horizontal line AB , fig. 41, 7.85 in. long as a base on which to draw the curve. Divide the circle of fig. 40 into a convenient number of equal parts, say 16, starting at "near dead centre," and divide the line AB into the same number of equal parts; each point of division then represents one of the points on the crank-pin circle. Next draw in the centre line of the connecting rod corresponding to each of the positions on the circle, and produce it (if necessary) to cut the vertical line through C in E . Now set off the length CE in

each case along the vertical to AB, fig. 41, at the corresponding point. Thus the value of CE shown in fig. 40, being that found for the second point on the circle, is set up at CE in fig. 41.* All the points being thus obtained, draw a curve through them, as shown. This is the curve of twisting moments, or, in other words, a curve showing the value of the tangential force PT at each point of the revolution. The area of each of the curves will be found to be equal to the area of the indicator card, as may easily be proved either from the principle of the conservation of energy or analytically by considering corresponding "elements" of each—i.e., thin vertical strips.

Curve for an Engine using Expansion.—In the former case the pressure on the piston is constant. The indicator card in that case is shown in full lines in fig. 42. If, however, cut-off takes place before the end of the stroke, the process must be modified. The proposed indicator cards (dotted lines, fig. 42) of the engine must be drawn for both ends of the

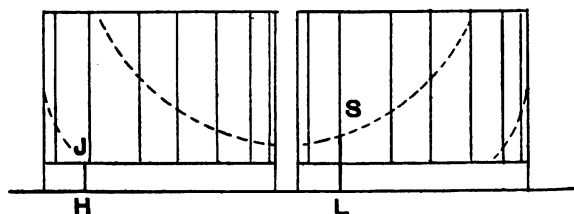

FIG. 42.

cylinder. Make the construction explained in connection with fig. 40 (i.e., draw in the centre lines of the connecting rod in each of its positions, and produce to cut the vertical) for all the points on the circle, the radius of the circle being the maximum pressure on the piston. Next find on the cards, fig. 42, the position of the piston corresponding to each of the points of the circle (by the

* In the original drawing, CE in fig. 40 was made = CE in fig. 41, but the drawings have been reduced in a different ratio.

crank circle-connecting rod construction we have so often used), and draw ordinates at these points, as shown in fig. 42. Calculate the total net pressure on the piston corresponding to each of these ordinates by deducting the corresponding back pressure, as found from the other card, and multiplying by the area of the piston. Set off these total pressures each along the corresponding crank in fig. 40. Suppose, for instance, we take the sixth ordinate on the return stroke—i.e., LS, fig. 42. The corresponding back pressure is HJ. Suppose LS is 0.73 in., and HJ is 0.42 in., the difference between them is 0.31. Suppose the indicator spring is

$$1 \text{ in.} = 40 \frac{\text{lb.}}{\text{in.}^2}.$$

This corresponds to a pressure per square inch of $0.31 \times 40 = 12.4$. Suppose the area of the piston is 28.2 square inches, the total net pressure on the piston must be $12.4 \times 28.2 = 350$ lb. Make the same calculation for each of the sixteen ordinates. Now, referring to fig. 40, mark off on each of the cranks such as CK the corresponding value CR of the total piston pressure to the same scale as before. Now, if the crank pin were at K, and there were full pressure on the piston, the value of the tangential force would, as already explained, be CI, but since the force on the piston is less than this in the ratio of CK to CR, it is clear that the actual tangential force will be not CI but CM where RM is parallel to DI. Thus, from each of the points on the base we must set up the corresponding value of CM, and draw a curve through the points as before. We shall thus get the curve shown dotted in fig. 41 instead of the full curve.

Combination of Curves.—If there are more than one cylinder acting on the shaft, curves must be drawn for each, and corresponding ordinates of each must be added together, and a curve drawn through the resulting points. Care must be taken that the pairs of ordinates added together represent the tangential force on the crank pin produced at the same instant by each cylinder. For instance, in the case of a

side-by-side compound, where the H.P. crank leads, the H.P. piston is about half-way through one stroke when the L.P. piston is beginning its stroke ; hence ordinate 4 in the H.P. curve must be added to ordinate O in the L.P. curve, 5 to 1, 6 to 2, and so on.

Having then obtained the curve of tangential forces, it remains to show how it may be used. Suppose the *total* work done by the engine (including, of course, that done against frictional resistances in the engine itself) be represented by the work done against a constant resisting force, acting tangentially against the crank pin ; or, if we like to express it so, suppose that the work done by the engine is represented by drawing up a weight by a rope wrapped round a drum keyed on the shaft, and whose diameter is that of the crank circle. If the mean speed of the engine is neither increasing nor decreasing, it is clear that the magnitude of this force or weight will be represented by the mean height of the two curves, fig. 41—that is, the total work done on the weight during one revolution will be equal to the area of the two halves of the curve. If this were not so, for instance, the mean rate of work done by the steam were consistently greater than that done in raising the weight, the excess would be stored up in the engine and flywheel, and weight, in the shape of increased kinetic energy—that is, the speed would continually increase until the engine or flywheel gave way (provided, of course, the engine could get enough steam).

Hence, if x be the weight,

$$x \times \text{crank radius} \times 2\pi = \text{area of two curves.}$$

This shows that the value x on our scale of forces is the mean height of the curves. Calculate, then, the value of x , and draw a horizontal line WXYZ, fig. 41, at this height above the base. Now, at the point W the steam commences to do more work on the piston than is absorbed by the work that is being done. As long as this is the case the engine will increase in speed—that is, up to the point X. Now, exactly at the end of the time during which the speed

is increasing, that speed must have attained a maximum value, for when the speed is not rising it must be either constant or falling. In the same way, exactly at the end of the time during which the speed is falling, it must have reached a minimum. During the interval represented by XY , the force driving the crank pin is less than the force x . Hence the speed is a minimum at Y , and a maximum again at Z , and so on. Now, during the interval WX , the amount of work that has been poured into the engine by the steam is represented by the area $wWEXx$, which area is equal to the corresponding space of the corrected indicator card. The actual amount of work in foot-pounds may be obtained by finding, as we have several times done, the area scale. In this case it is 1 square inch = 4 in. \times 1000 lb. = 4000 inch-pounds = 333.3 foot-pounds. Similarly, the amount of work drawn off by the external work in this interval is the area $wWXx$, whence the difference which is poured into the flywheel is WEX . Now, the speed is a minimum at W , and a maximum at X , and the difference between the energies of the flywheel in the two cases is the amount of work represented by WEX . Suppose this area is 1.64 square inches, representing $1.64 \times 333.3 = 546$ foot-pounds.

The total variation of speed is to be not greater than 5 per cent of 250; or, say, 12.5 revolutions per minute. Fix the minimum at 244, and the maximum at 256. The rim must then be of such a weight that the addition of 273 foot-pounds of work to it, when it is running at 244, does not raise its velocity to more than 256.

Let x be the required weight, and, say, 2.5 ft. its diameter.

$$\text{Rim velocity at 244} = \frac{2.5 \times \pi \times 244}{60} = 32 \frac{\text{ft.}}{\text{sec.}}$$

$$\text{Energy at 244} = \frac{x \times (32)^2}{2 \times 32} = 16x.$$

$$\text{Velocity at 256} = \frac{2.5 \times \pi \times 256}{60} = 33.5 \frac{\text{ft.}}{\text{sec.}}$$

$$\text{Energy} = \frac{x \times (33.5)^2}{2 \times 32} = 17.5x.$$

$$\begin{aligned} \text{Hence,} \quad 17.5x - 16x &= 546. \\ 1.5x &= 546 \\ x &= 364 \text{ lb.} \end{aligned}$$

In case we are required to be more accurate still by including the weight of the arms, &c., of the wheel in the calculation, we must find the moment of inertia of the flywheel about its axis in lb. ft.² This can be done by a construction described in the author's book on "Graphical Calculus." The energy is then $\frac{1}{2} g I w^2$, where w is the angular velocity in radians per second, and I is the moment of inertia. In the case of a flywheel, an approximation which is sufficiently accurate for all practical purposes is embodied in the following rule: Calculate the weight of all the arms, divide by 4, and add to the weight of rim.

The effect of the moving parts of the engine can also be measured by methods explained in the work referred to above, but in practice it would be a useless refinement to take count of them.

CHAPTER VII.

THEORY OF THE INERTIA OF MOVING PARTS.

It is well known that when an engine is running rapidly it causes, or tends to cause, more or less violent shaking of the foundations to which it is bolted. In some cases the shaking of even very heavy and rigid foundations is so severe as to prevent the use of the engines altogether, owing to the annoyance to residents and damage to property in the vicinity. Thus, at the central electric lighting station at Manchester Square, London, the shaking due to this cause was so great that the engines of large power had to be replaced at huge expense by steam turbines. These effects can be partially, but only partially, counteracted by what is called "balancing," the meaning of which

term will appear as we proceed. It will be readily understood that part of this effect is due to the rotation of the crank shaft if this is so made that (1) its centre of gravity does not lie on the centre line of the shaft; (2) its axis of rotation is not a "principal axis." Just as a stone being swirled round at the end of a piece of string causes a centrifugal pull upon the string, so the swirling round of the crank shaft of an engine causes a pull upon the foundations, the direction of which continually varies.

In order to obtain clear ideas of the cause of this pull, and to understand the additional effect of the reciprocation of the moving parts, we shall briefly analyse the motions.

If a stone weighing, say, 3 lb. is moving in the direction A, fig. 43, and, say, two seconds afterwards is moving in direction B with the same velocity, the change being due to a constant force x pounds acting on the stone in direction B, it is easy to find the value of x as follows: The total change of velocity is 4 ft. per second in direction B; for a change of 2 ft. per second brings the body to rest, and a further change of the same magnitude gives it the opposite velocity B. This change of velocity takes place in two seconds. The change of velocity per second is therefore 2 ft. per second, and the force is

$$\frac{\text{mass} \times \text{acceleration}}{g} = \frac{3 \times 2}{32} \text{ lb.} = \frac{3}{16} \text{ lb.}$$

Now, this method will also apply in the following case: Required the value of the force acting always parallel to B, fig. 44, which will, in two seconds, change a velocity P of 4 ft. per second into one of the same magnitude in direction Q. Now, a body having velocity P of 4 ft. per second is moving towards the line RS at the rate of 2 ft. per second, and, if with velocity Q, away from the line with the same velocity. To find the force perpendicular to this line required to produce this change in two seconds, we have to find the necessary change of velocity per second towards or away from RS—that is, parallel to B. Clearly this is, as before,

2 ft. per second every second, and the force is therefore the same as before, viz., $\frac{1}{18}$ lb., acting always parallel to B. Now, this is precisely the method adopted in finding the value of a force which will keep a stone or other

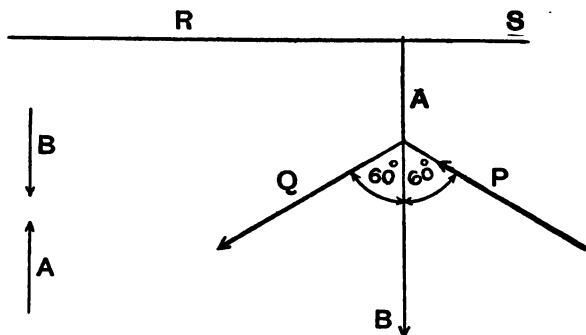

FIG. 43.

FIG. 44.

body swinging round in a circle with a constant velocity, but we have to take the angle between P and Q as extremely small in order to calculate the force. Take a numerical example: CA, fig. 45, is a piece of string 3 ft. long; A is a stone weighing, say, 7 lb. A and B are supposed to be extremely near together, but are shown in fig. 45 some distance apart, for clearness sake.

Suppose the angles DCA, DCB to be each '001 radian; that is,

$$\frac{DB}{CB} = \frac{AD}{CA} = '001.$$

Suppose the velocity with which the stone is moving to be 6 ft. per second, and represented by AE at the beginning of the interval, and BH at the end. The angular velocity is then $\frac{2}{3} = 2$ radians per second.* Distance from A to B along

* If this be not understood, see definition of a "radian" in any book on elementary trigonometry.

and force in direction D C required to produce this acceleration in a mass of 7 lb. must be

$$\frac{7 \times 12}{32} = \frac{84}{32} = \frac{21}{8} \text{ lb.}$$

We should have obtained the same result whatever angle we had fixed upon for A C D, provided it is so small that E F is indistinguishable from a circular arc having A as centre. The student should convince himself of this by taking a different angle for D C A.*

Now, in order to make this reasoning general, we have only to use symbols instead of figures.

Instead of 7 lb., use m .

„ 6 ft. per second, use $v = A E = B H$.

„ .001 radian, use $d\theta = \text{angles D C A, D C B, \&c.}$

„ 3 ft., use $r = C A$.

Angular velocity then $= \frac{v}{r} = w$, suppose.

Distance from A to B $= 2 r d\theta$.

Time required to travel from A to B $= \frac{\text{distance}}{\text{velocity}} = \frac{2 r d\theta}{v}$.

Length of E F $= v d\theta$.

Change of velocity per second $= \text{“centripetal acceleration”}$

$$= \frac{\text{total change of velocity}}{\text{time occupied}} = \frac{2 v d\theta}{\frac{2 r d\theta}{v}} = \frac{v^2}{r}.$$

The direction of this acceleration is along the radius.

Force parallel to D C required to produce this change

$$= \frac{m v^2}{g r}; \text{ or, since } \frac{v}{r} = w,$$

$$\frac{m v^2}{g r} = \frac{m w^2 r}{g}$$

which latter form is much easier to use.

* This reasoning is only absolutely true and free from all approximation “in the limit” when D C A is taken infinitely small, for in that case (1) the radius is always infinitely near to D C, (2) F E is infinitely near to $v d\theta$. It is an approximation, but an extremely close one, when D C A is very small, but finite. Two quantities are said to be mathematically equal when they only differ by an infinitely small quantity. Such a quantity is called a “vanishing quantity,” or “zero quantity,” in the limit.

The value of w may be calculated thus : $w =$ radians per second $=$ revolutions per seconds $\times 2\pi$, since there are 2π radians in one revolution. This digression into elementary mechanics has been made because this principle of centrifugal force is often not understood, and there is no hope of understanding what follows unless it is perfectly familiar. To calculate, then, the centrifugal force of any body moving in a circle, use the following formula :—

$$\text{force} = \frac{\text{weight} \times (\text{revs. per sec.} \times 2\pi)^2 \times \text{radius in feet}}{32}$$

The radius used must be that of the path of the centre of gravity, as may easily be proved by the application of the integral calculus. Thus, when the crank illustrated in

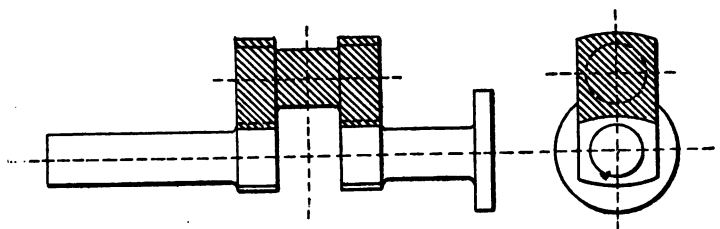

FIG. 46.

fig. 46 revolves in its bearings, the centrifugal force on each of the shaded parts of the cranks and the pin can be calculated separately and added together to find the total force on the bed plate.* The resultant force at any instant will act through the centre of the pin parallel to the centre line of the cranks. This is the first force with which we have to deal.

The next force we shall consider is that due to the reciprocation of the piston and connecting rod, which we shall at present treat all together, neglecting the lateral swaying of the connecting rod. First suppose a horizontal engine is

* See the remarks on this subject given in connection with fig. 57, on page 128.

being driven by a belt at its ordinary speed, without any steam being admitted. Now, just before the pin reaches either dead centre these parts are moving in one direction, and just after that point is passed in the opposite one. There must, of course, be some horizontal force acting on them to produce this effect. This force is supplied to the parts through the crank pin. Now, the crank pin cannot pull these parts about in this way unless it is itself pulled by something else, any more than a hydraulic jack can lift a boiler without being firmly supported on the ground. The jack presses the ground down just as hard as it lifts the boiler up, and, over and above centrifugal and gravitational forces, the crank-shaft bearings pull the crank pin in a horizontal direction just as hard as the crank pin pulls the piston, &c., so that ultimately the real force that moves the reciprocating parts comes from the resistance to motion, or inertia, of the foundations, if we consider them as separate from the earth as a whole. The moving parts cannot acquire any momentum without the foundations at the same instant acquiring an equal and opposite momentum. It is these vibrational movements of the foundations which have to be guarded against as far as possible. Speaking generally, the method adopted is to so arrange the moving parts of the engine that when one part acquires a momentum in one direction, some other part of the engine itself acquires an equal momentum in an opposite direction, so that the foundations do not have to take up more of the surplus momentum than is absolutely necessary. If this is done, the reactionary force which produces these equal and opposite momenta comes from a stress in the bed plate, so that the engine is, as it were, self-contained in respect of its momentum. If balancing is done perfectly, the engine theoretically requires no foundations at all. Foundations, in fact, act as a sort of reservoir of momentum; they cannot do so without vibrating, any more than a flywheel can act as a reservoir of energy without changing its velocity.

Now, since momentum = mass × velocity, it is clear that if the foundations take up a given quantity of momentum, the greater their mass* the smaller will be the velocity generated. If the foundations have very small mass, as in the case of a portable engine, we must be especially careful to reduce the momentum that has to be taken up—that is, the engine must be carefully “balanced.”

It is rather more difficult to understand the effect when steam drives the piston. Here one might be tempted at first sight to think that the steam pressure would supply the force necessary to move the piston, &c., without drawing on the reservoir of momentum constituted by the foundations. It must not, however, be forgotten that when pressure steam acts upon the piston it also acts upon the cylinder cover. A certain proportion of the pressure of the steam on the piston is *absorbed* in increasing the velocity of the reciprocating parts. This absorbed force never reaches the crank pin until the velocity of the parts is again reduced. Suppose, for instance, that at a certain point near the commencement of the stroke the total force on the piston is 2,000 lb., the weight of moving parts being 62 lb., and their acceleration 120 ft. per second. The force required to produce this acceleration is then

$$\frac{62 \times 120}{32} = 232 \text{ lb.}$$

This force is absorbed by the piston, &c., in exactly the same way as a cannon ball absorbs the whole of the powder pressure. The remainder of the force—viz., 1,768 lb.—is the horizontal force which acts on the crank pin, and is transmitted through the bearings to the bed plate as a forward force. Now, the steam in the cylinder, in addition to pressing the piston forwards, also presses the cylinder

* A great many engineers have a strong objection to the word “mass.” It has, nevertheless, a definite meaning, which is fundamentally different from that of the word “weight.” The subject cannot be treated scientifically without distinguishing between the two words. The student is referred to Chapters II. and III. of Hicks’ “Dynamics,” where he will find the difference fully explained.

cover backwards (just as the explosion in a gun generates the backward pressure which produces the recoil). The magnitude of this pressure is 2,000 lb. This again is transmitted through the cylinder bolts to the bed plate, so that we have acting on the bed plate a forward force of 1,768 lb. and a backward force of 2,000 lb., the difference—viz., 232 lb.—tending to move the bed plate and foundations backwards, and thereby generating in them a backward momentum. This is, as may easily be seen, precisely the same force as would act on the bed plate if there were no steam acting on the piston, as in the first case we considered. We have therefore a total net longitudinal stress of 1,768 lb. in the bed plate itself, the forward push and part of the backward push being here neutralised as far as production of momentum is concerned, while the balance of momentum is neutralised from the foundation reservoir.

It will be thus seen that we have two sets of forces to deal with: (1) Centrifugal forces, due to the swinging round of the cranks, crank pin, and part of the connecting rod. These forces act in the central plane of the engine in the direction of the centre line of the crank, which direction rotates continuously. (2) Inertia forces, which act always in the direction of the piston rod, and opposite to the direction of acceleration of the moving parts; that is to say, when these parts have a forward acceleration the inertia force acts backwards, and *vice versa*.

Both these forces tend to pull the foundations in the direction in which they act. We shall show in the next chapters the best way of dealing with them.

CHAPTER VIII.

INERTIA DIAGRAMS.

THE inertia of moving parts of an engine has also an effect on the curve of twisting moments, which becomes of great importance in high-speed engines.

We showed in the last chapter that a certain proportion of the steam pressure acting on the piston is absorbed in increasing the velocity of the reciprocating parts during about the first half of the stroke. During the remaining part of the stroke these parts are gradually brought to rest. In this process the kinetic energy stored in the moving parts is utilised in doing work on the crank pin. There is no net gain or loss of work due to this cause—that is to say, exactly the same amount of work as is absorbed or stored in the parts during the first half of the stroke is restored during the last half. The work so transferred is taken out of the steam when it can best afford to lose some energy, and is carried forward to help the expanded steam when it needs it, tending therefore to equalise the effective pressure throughout the stroke.

To determine, then, the exact twisting moment, we shall have to make allowance for this extra force due to acceleration or retardation of the piston, &c. This process is called “correcting the indicator card for inertia.” We shall then have to draw the curve of twisting moments from the corrected card, exactly as we have already done (fig. 41) from the uncorrected one.

The effect of inertia at any point of the stroke is usually estimated in pounds per square inch of piston area. Thus, if we find in an engine whose cylinder diameter is 10 in., and area 78·5 square inches, by 8 in. stroke, and whose normal speed is 500 revolutions per minute, that the force

required to accelerate the moving parts is 1,326 lb., at, say, $\frac{3}{8}$ stroke ; then, if the steam pressure were

$$\frac{1326}{78.5} = 17 \text{ lb. per square inch,}$$

the whole of that pressure would be absorbed at that point in accelerating the moving parts, and, therefore, if the actual pressure in the cylinder at this point is 92 lb. per square inch, the actual effect on the crank pin will be the same as would be produced by a stationary pressure of

$$92 - 17 = 75 \text{ lb. per square inch.}$$

Thus, if the accelerating or retarding pressure be calculated, as will presently be explained, for several positions of the crank, and this pressure be deducted from, or added to, the pressure, as shown at the same point on the indicator card, we can draw a new indicator card showing the corresponding value of the stationary pressure at each point.

It is perhaps more straightforward and convenient to first deduce from the proposed actual indicator card another diagram, by altering the heights of the card at its various points in a fixed proportion, such that the heights of the new diagram show on a different scale the values of the total pressures on the piston, and deducting from, or adding to, each ordinate a length which gives on the same scale the corresponding value of the total force required to accelerate or retard the moving parts ; the net stationary forces may then be transferred direct to the radii of the circle in fig. 40 without any calculation.

It remains, then, to explain a construction whereby the acceleration may be exactly found at any part of the stroke.

Calculate the value of $w^2 r$, or, what comes to the same thing, $\frac{v^2}{r}$, for the normal speed of the engine. This gives, as explained in the last chapter, the centripetal acceleration of the centre of the crank pin.

As an example, take the case of the 10 × 8 engine referred

and the eleventh, counting near dead centre as one. Each of these are correspondingly lettered, the latter being dashed.

Produce P Q to H, draw H R horizontal to meet the crank produced if necessary, draw R S vertical to meet the connecting rod, and draw S T, perpendicular to the connecting rod, to the line of centres. Then C T represents the acceleration of the piston to the same scale as C Q represents the centripetal acceleration of the crank pin.

To completely understand the proof of this proposition requires a somewhat more thorough knowledge of mechanics than is assumed in this book. It may be briefly indicated as follows:—

C H represents the velocity of P to the same scale as C Q represents the velocity of Q. This may be proved from the fact that at the instant during which the crank is in the position C Q the connecting rod has the same motion as regards the velocity, but *not the acceleration*, of its ends, as it would have if it were turning about the point L as centre. Therefore

$$\frac{\text{velocity of P}}{\text{velocity of Q}} = \frac{LP}{LQ} = \frac{CH}{CQ}.$$

Thus,

$$\text{velocity of P} = CH \times \frac{\text{velocity of Q}}{CQ},$$

which, imagining the drawing full size, = C H w where w = angular velocity of crank. Hence, differentiating,

acceleration of P = $w \times$ rate of increase of C H . . . (a).

Now, the upward velocity of H (= rate of increase of C H) is compounded of a motion H K perpendicular to L H, and a sliding K N along H P; hence L M H is similar to the triangle of velocities of H turned through a right angle, whence

$$\frac{\text{upward velocity of H}}{\text{velocity of Q}} = \frac{LM}{LQ} = \frac{CT}{CQ},$$

to work as that already given, owing to the confusion introduced by the large number of circles that have to be drawn; it is as follows:—

To find the acceleration at the point P, fig. 48, draw a circle on the connecting rod as diameter, and another with P H as radius. The common chord of these two circles cuts the line of centres in the same point T as is obtained by the other construction.

Now, we may calculate from the acceleration the force required to produce it by multiplying by $\frac{M}{g}$ where M is the total weight of reciprocating parts and g the acceleration due to gravity—*i.e.*, 32.2 ft. per second per second; but it is more direct to proceed as follows:—

Instead of making the radius of the circle = centripetal acceleration of the crank pin, as in fig. 47, make it = this quantity multiplied by $\frac{M}{g}$. The radius then represents

what the value of the centrifugal force would be if all the moving parts were concentrated into one cylindrical block whose centre coincided with the centre of the crank pin. Perform precisely the same construction as before with the new value of the radius, and the lengths C T will represent direct the horizontal force required to accelerate or retard the moving parts to the same scale as the radius represents the imaginary centrifugal force. When the point T is to the right of C, the force is an additional horizontal force on the crank pin—*i.e.*, the force C T must be *added* to the total force in the piston. Each of the values C T must now be plotted on a base representing the corresponding position of the piston in its stroke. The curve thus obtained is shown in fig. 49. It is to be noted that the inertia curve for the downstroke is precisely the same as that for the upstroke—that is to say, when the piston is at N on the downstroke the pressure between connecting-rod brasses and crank pin due to inertia (N M) is precisely the same as on the upstroke when the piston is in the same

position N. It is clear that in this curve, since ordinates represent forces and abscissæ distances through which these forces act, the area of the curve will represent total work done, as we have several times explained. Thus the area CAE represents the total work done in generating the maximum velocity in the moving parts—that is, the kinetic energy of those parts when moving with their greatest velocity. EBD represents the work done by the moving parts in being brought to rest. It will be found in every case that these two areas are exactly equal.

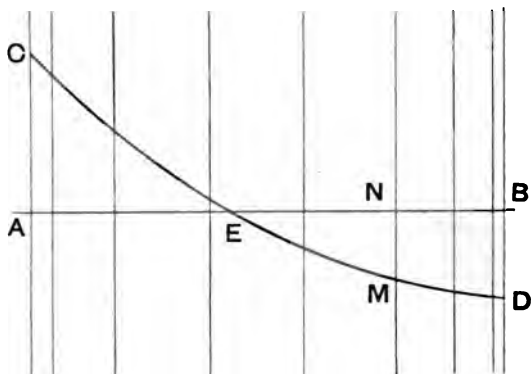

FIG. 49.

The corrected total force card is derived, as already explained, by subtracting each ordinate of fig. 49 from the corresponding ordinate of the total force card. The resulting diagram, the lowest one in fig. 50, is such that any ordinate JK = JK in the upper figure. It will be seen that this card shows a much more uniform pressure than the total force card.

This diagram is used, as already explained, in the construction for the twisting moment curve.

In a vertical engine we have also to allow for the dead weight of the moving parts, which acts always downwards.

In a high-speed engine this allowance is almost insignificant compared to the inertia allowance. If the diagram in fig. 50 represents downward forces—*i.e.*, represents the indicator card taken from the upper side of the piston—the dead weight represents a constant force added to the force due to steam pressure. Hence it is allowed for by adding to each ordinate

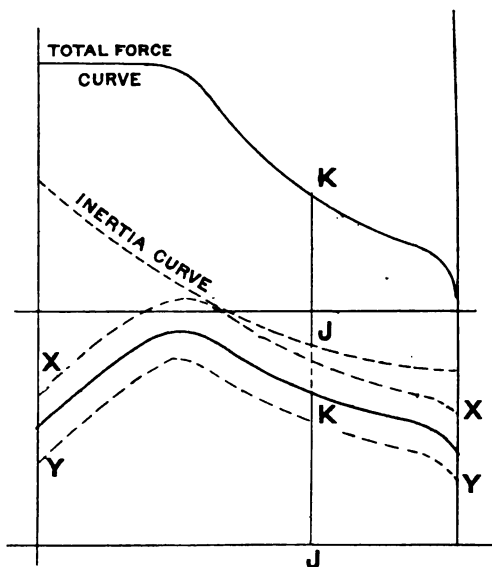

FIG. 50.

a constant length representing the weight of the parts to the proper scale, as shown in the upper dotted curve X X. If this card is taken from the underside of the piston, the correction is shown in the lower dotted curve Y Y, for here the weight represents a force acting in the opposite direction to the steam pressure.

This inertia card is extremely useful in designing a single-acting high-speed engine.

When an engine is required to run at a very high speed, the "knock" in the brasses, due to reversal of stress, is so destructive that reversal has to be entirely avoided by keeping the connecting rod always either in tension or compression, usually the latter, as the former involves a stuffing box and gland. Now, the force required to bring the parts to rest is so great, at even a moderate speed, that the weight

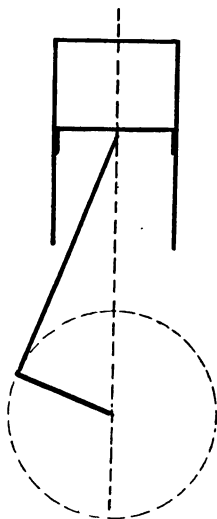

FIG. 51.

of the parts is not sufficient (we are speaking of vertical engines), and therefore, unless special precautions are adopted, reversal will take place towards the end of the upstroke, in spite of the fact that there is no steam on the underside of the piston. Thus, in the diagrammatic engine of fig. 51, steam being only admitted on the topside of the trunk piston, although the steam pressure keeps the rod in compression during the whole of the downstroke (unless, of

course, the pressure is so low, and speed so high, and piston, &c., so heavy, that the necessary accelerating force early in the stroke is greater than the total pressure on the piston, and the inertia of the parts during the first part of the upstroke, yet during the latter part of the upstroke, unless there is some pressure behind the piston to produce the retarding force, reversal will take place, because, otherwise, a pull will come on the crank pin and a knock when steam is admitted. To avoid this we must cushion the steam above the piston at such a point that the force behind it is always greater than the required retarding force. It is the object of the present construction to find this point. When it is found we must arrange our angle of advance and inside lap accordingly.

Set out $O X$, $O Y$, fig. 52, at right angles as axes on which to draw the total pressure indicator card; draw aa , the atmospheric line, at a height representing on a scale of forces $14.7 \times$ piston area; and take $O Z$ to represent the clearance to scale, and $Z X$ to represent the stroke volume to the same scale. Draw then the inertia curve on the atmospheric line as base, showing total accelerating forces on the upstroke of the piston, in such a way that inertia forces tending to make the piston fly upwards are plotted upwards, and *vice versa*. Thus at P , in fig. 52, the force tending to lift the piston and connecting rod is the vertical distance between P and the inertia curve.

The reason for the inertia curve being drawn on the atmospheric line as base is that the atmosphere is constantly pressing on the underside of the piston, tending to lift it, and therefore a neutral value of the pressure on the piston—*i.e.*, a value which produces no net upward or downward pressure—is that of the atmosphere, *viz.*, 14.7 lb. per square inch. At any pressure below this there is a net upward pressure, and above this a downward one; and since we are comparing in this construction the *net* force on the piston with the total inertia force, we are obliged to reckon from a neutral pressure—*i.e.*, the pressure of the atmosphere.

Now, we have to assume a back pressure during the first part of the upstroke. This must be taken rather low, so as to be on the safe side—say 17 lb. per square inch absolute for non-condensing engines. Multiply the piston area by 17 lb. per square inch, and draw the corresponding horizontal line S to represent the first part of the bottom line of the proposed indicator card. Now, the cushioning line will be an

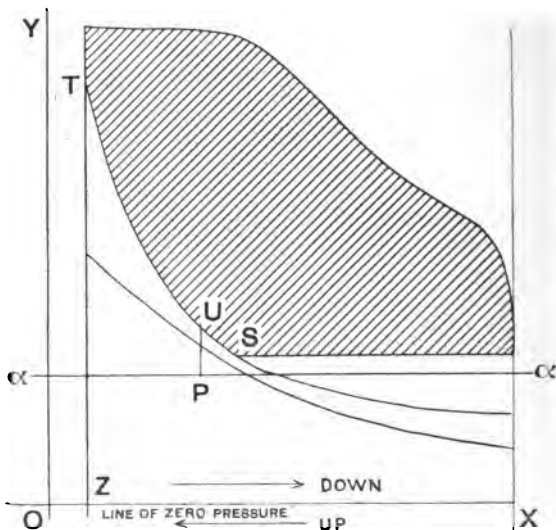

FIG. 52.

hyperbola, with $O X$, $O Y$ as asymptotes. The hyperbola will lie as shown at ST in the figure, the height of which at any point shows the total pressure on the piston due to compression. Now, this hyperbola must lie *entirely above* the inertia line. If it fell below it, it would signify that at some points of the stroke the upward tendency of the moving parts was at those points greater than the downward pressure of the steam, and consequently, at each point

where the two curves crossed, there would be a knock due to reversal of stress. The curves will be nearest at some point at about the position U. Take, then, a point U slightly above the inertia line, the difference between them representing about 10 per cent of the *total* pressure on the piston, and draw an hyperbola each way to cut the line RS in S. S will be the point where compression must commence. If it be found on trial that the hyperbola through the point U first selected cuts the inertia curve, take another point higher up, and proceed as before, till an hyperbola be found which lies entirely above the inertia curve. It will be seen that it is almost impossible to have an engine of this type condensing, because in that case compression would commence so early that exhaust would have to be closed almost before it was well opened.

The weak point in this construction is our ignorance of the exact value of the back pressure, which we are compelled to assume from previous experience. It may happen that the actual back pressure will considerably exceed our estimate, in which case the compression force on the piston will be considerably greater than is necessary. If, on the other hand, the back pressure is lower than the estimate, the result may be that we shall find the engine knocking, in spite of all our precautions. In addition, the inability to use a condensing engine without a gland and stuffing box is a serious drawback.* Likewise, since we are obliged to design the engine for one particular speed, and since we cannot alter the point of compression once the valve is made, we cannot vary the speed of the engine from the designed value without either having (1) excessive compression if the speed is reduced, or (2) knocking if the speed is increased; also, the restrictions which the early compression places on the valve design are extremely incon-

* The leakage of air past the piston into the condenser when the engine gets slightly worn prevents this being done. It will be found useful to put a stop valve on the exhaust pipe, in order to throttle the exhaust as much as may be necessary to stop knocking. This allows greater latitude in the design.

venient. A valve cannot be designed to satisfy innumerable requirements. The transfer of one of the functions of the valve to an independent part of the engine is a great convenience, as it allows us more liberty to meet other pressing requirements in the valve design. For these reasons the compression necessary to keep the back brass always in contact with the pin has been in the Willans engine transferred to a separate cylinder, in which an adjustable quantity of air instead of steam is compressed. The method to be used in this case is identical in principle with that already discussed—i.e., draw a composite total force card by adding together all the total force cards from

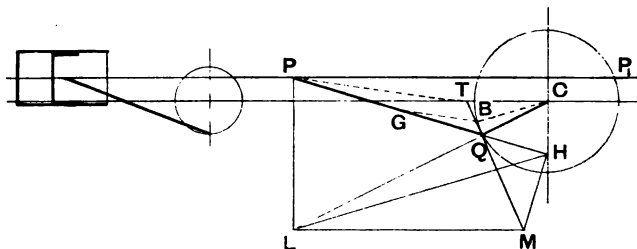

FIG. 53.

the pistons acting on one piston rod. Calculate the total weight of moving parts, and derive the inertia curve. Then, by adjusting the pressure in the air cylinder, bring the total back-pressure force line above the inertia curve at all its points. The rod will then be always in compression.

Single-acting engines are sometimes made in which the centre line of the cylinder does not pass through the centre of the crank shaft. The reason for this construction is that the obliquity of the connecting rod is diminished at those parts of the stroke during which the greatest pressure comes on the piston, and, therefore, wear on the sides of the cylinder is saved. The following construction may be used in these cases to find the acceleration at any part of the

stroke: The same construction being made as before, PP_1 (fig. 53) being the line of stroke of the piston, and C the centre of the shaft, produce PQ to H . Draw LMH the triangle of velocities of the point H turned through a right angle (see fig. 47). Join MQ , and produce to cut the line through C parallel to the line of stroke in T , then CT gives the acceleration of the piston to the same scale as CQ gives that of the crank pin.

Other cases sometimes arise, due to peculiar connection between the piston and the crank pin. They can always be solved analytically by the application of the differential calculus; but the expressions for the acceleration are in some cases very cumbrous. The following general method is applicable in all cases, but is not easy to work accurately unless great care is taken in the exact determination of a large number of points on the curves:—

1. Find by construction the position of the piston for a large number of points on the crank circle.

2. Plot the distance of the piston from its central position on a base which represents the crank-pin circle unrolled into a straight line. Draw very carefully a curve through the points.

3. Mark the base out into distances traversed by the pin in one second—one-half, quarter, or other convenient units. The higher the speed, the smaller must the time interval be taken.

4. To find the acceleration at any point P on this curve draw PM horizontal, make PM equal to the distance travelled by the pin in one second or other time unit. Draw PT tangent to the curve, and make MT vertical. The length of MT gives the velocity of the piston at P in units, which must be determined from common-sense principles by making a scale of velocities.

5. Plot the length MT at $p'P'$, as shown all along the time base, each ordinate of the second curve being plotted vertically below the corresponding point on the first, and draw a curve P' through the points.

6. Treat the point P' precisely as the point P was treated, and find the third curve in precisely the same way from the second as the second was found from the first. The third curve is the curve of accelerations, but the units with which

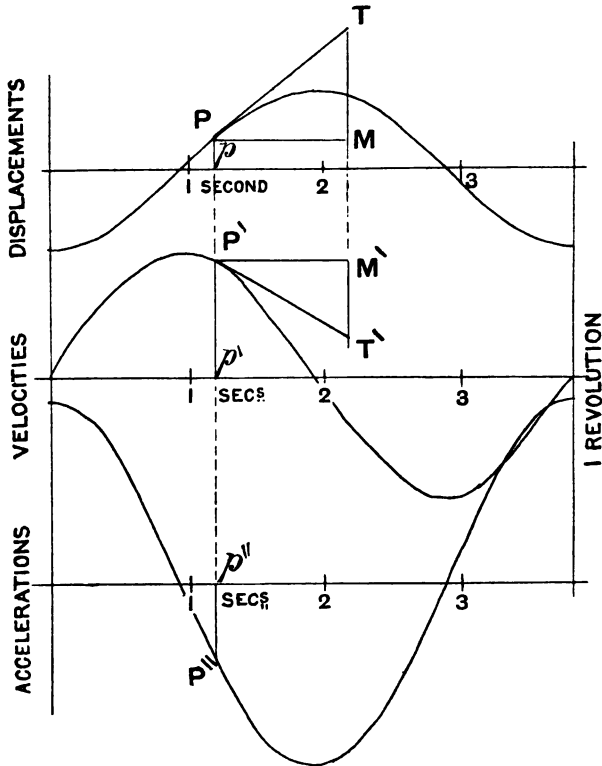

FIG. 54.

it is to be measured must be exactly determined before it can be used practically. This construction corresponds to differentiating the expression for the displacement successively with respect to the time. The principle of the construction is fully explained in "Graphical Calculus."

CHAPTER IX.

THE MOTION OF THE CONNECTING ROD.

WE have previously treated the connecting rod as though it were part and parcel of the piston rod, and had the same horizontal acceleration. This, though sufficiently accurate for the purposes for which we have used the construction, is only an approximation to its actual motion. But for its ever-varying obliquity, the horizontal motion of the rod would be exactly that of the piston rod. We shall now explain constructions by which the motion of the connecting rod may be exactly determined, but it need only be used where very exact accuracy is required, as in designing high-class standard high-speed engines, of which a large number are required. If the position of the centre line of the connecting rod be drawn in in all the sixteen positions we usually consider, and the same point be found in all of them, we can follow the motion of any point throughout the whole revolution. It will be found that while the crosshead end describes a straight line,

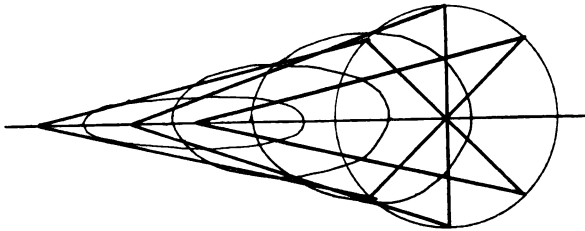

FIG. 55.

and the crank-pin end a circle, any intermediate point describes a curve which is a sort of distorted compromise between the two. An ellipse is a natural compromise between a straight line and a circle, and these figures are

distorted ellipses which are bilaterally symmetrical about the centre line. For points near the crosshead the curve is a flat oval figure, which opens out gradually as the point is taken nearer and nearer the crank pin, as shown in fig. 55. The velocity of these various points is a matter which does not concern us much, except in so far as it has an effect on the acceleration, though it can easily be found by the exercise of a little ingenuity on fig. 56. The actual acceleration of any point is composed of two parts: (1) The acceleration of the point along its own path; (2) its centripetal acceleration along the normal to the curve which it describes.

To find each of these separately, and to compound them graphically, would be an extremely difficult task, but a construction will now be explained whereby the resultant of these may be found with very little trouble. We cannot avoid, however, taxing the geometrical imagination* of the student in explaining the reason of the construction. Of course it is assumed that by this time he can draw a distinct mental picture of the difference between a velocity and an acceleration. The point Q, fig. 56, has a velocity along $Q t$ and an acceleration along $Q C$ whereas the point P has a velocity and an acceleration both along $P C$. It may be added, as a preliminary observation, that a clear conception of the co-existence of a velocity in one direction and an acceleration along another direction may be obtained by considering a stone thrown into the air. It has a velocity along its own path and an acceleration always vertically downwards (neglecting, of course, the resistance of the air). The result is that the stone describes a parabola, whose axis is parallel to the direction of acceleration, so that when any body has a simultaneous velocity and acceleration in different directions it is to be imagined as describing a

* The training of this faculty is perhaps the chief advantage to an engineer of the study of mathematics, and without that training he cannot hope to understand many of the extremely confusing problems with which he will be constantly confronted in the higher branches of the subject.

small part of a parabola* whose axis is parallel to the acceleration. Again, velocity and acceleration are absolutely independent of one another. The sudden addition of a simple velocity to a body makes *per se* no difference to the acceleration with which that body is moving for just the same reason that if the water in a tank, into which a tap is

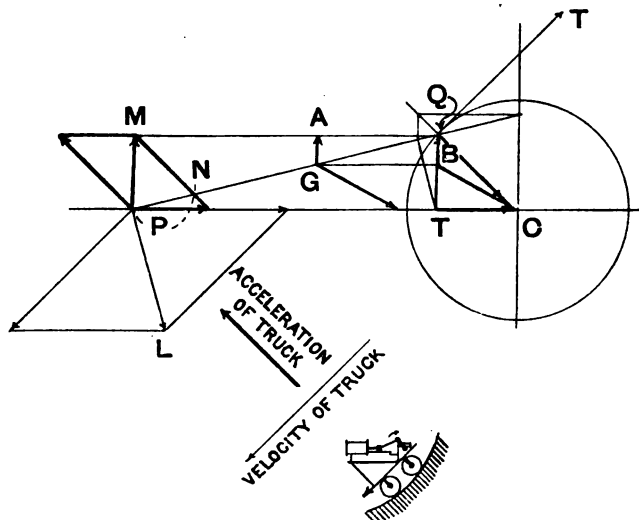

FIG. 56.

running, is rising at the rate of 2 in. in one minute, it will continue to rise at the same rate after a bucket of water is suddenly thrown into it.

Imagine, then, that the whole engine is on a truck which is travelling with a velocity exactly opposite to the velocity of Q , at the instant shown in the diagram. Now, if an observer were watching the engine from the ground, Q would appear to be standing still for a single instant, C

* A small part of a circular arc may, when necessary, be imagined as coinciding with a small part of this imaginary parabola.

would have the same motion as the truck, and P would have a motion PL, compounded of its own velocity along PC, and the velocity of the truck, as shown. Now, in addition to this, the truck must be assumed to have an acceleration $\omega^2 r$, opposite to the centripetal acceleration of Q. Velocities in the figure are indicated by thin arrows, and accelerations by thick ones. It may be imagined to have this compound motion due to travelling on a switchback railway, which is in elevation a parabola, as described above. This then brings the point Q for an instant to rest, both in respect of its velocity and of its acceleration, although not necessarily in respect of its rate of change of acceleration. Now, under these circumstances, the point P would have an acceleration compounded of its own along PC, and $v^2 r$ along a line parallel to the crank. This resultant acceleration is shown at P M. Thus, point P would, at the instant under consideration, be travelling along the parabola PN, shown dotted. Now we can pick out the acceleration of G, since Q is at rest. It will be obviously a reduced copy of P's acceleration—i.e., GA. Now, PM = TQ, and GA = BQ, so that BQ will represent G's acceleration. Now we can see what G's acceleration will be in a stationary engine by imagining the truck suddenly at this instant brought to rest; obviously, the acceleration of G will be a compound of BQ with QC, for CQ was the acceleration of the truck. The resultant of these two is clearly BC. Hence, to find the acceleration of any point G in the rod, make the construction for acceleration of P, draw GB parallel to PC, and join BC; BC is the required acceleration to the same scale as CQ represents the centripetal acceleration of the crank pin. A modification of the same construction may be applied to fig. 53, as shown in dotted lines. Join PT, and draw GB parallel to PT; then BC is the required acceleration. The proof is similar to the one we have given. It may also be applied to any construction.

Let G, fig. 56, be the centre of gravity of the connecting rod, and let BC be its acceleration. Now, when the centre

of gravity of any body whatever has a resultant acceleration at any instant in any direction, it is a sure proof that the resultant of *all* the forces acting on the body from outside (we will not at present trouble about the stress forces—action and reaction—in the body itself) acts in that direction, and is of magnitude $\frac{M}{g} \times$ acceleration in feet per second per second where M = mass of body in pounds. This is a fundamental natural law, which is subject to no exception under any circumstances.

We can at once infer that the combined force with which the crosshead pin and the crank-pin press on the connecting rod acts in direction BC , and is of magnitude $\frac{M}{g} \times BC$, BC being measured in proper units. This is another way of saying (bearing in mind the principles previously explained), that the motion of the rod exerts a resultant force of this magnitude on the foundations.

But this is not the only effect of the peculiar motion of the connecting rod. It is continually changing its angular velocity—that is to say, the rate in radians per second at which its inclination to the horizontal is changing, is itself continually changing. This angular velocity is zero when the crank is at right angles to the line of stroke, and is a maximum when the pin is crossing dead centres.

Now, when an angular velocity is changing, the rate in (radians per second) every second at which it is changing is called its angular acceleration. A law exactly analogous to that explained above, and as rigidly accurate under all circumstances, governs this rate of change and the couple which produces it. It is as follows:—

Couple in pounds-feet = $\frac{I}{g} \times$ angular acceleration where I is the moment of inertia* in pounds-feet². If the couple

* The student who is not acquainted with the meaning of moment of inertia and the method of finding it is referred to Hick's "Elementary Dynamics" and the author's "Graphical Calculus." It cannot be explained here.

is required in pound-inch units, I must be expressed in pound-inch units, and also g in inches per second per second.

The magnitude of the angular acceleration may be found by finding the component of $P M$, fig. 56, at right angles to the rod, and dividing the actual value of this component of the acceleration $P M$ in $\frac{\text{feet}}{\text{sec}^2}$ by the length (in feet) of the rod.

This component in fig. 47 is $T S$, the point S not being lettered in fig. 56.

The moment of inertia must be found by the method explained in "Graphical Calculus," and the couple deduced by the application of the above formula. This couple, of course, as before, acts on the foundations, and tends to turn them upside down in the central plane of the engine. A couple has no point of application, because the effect of a couple on the movement of a body is precisely the same as that of any other couple of equal moment acting on the same body in any parallel plane. The effect of it is to produce a tension and pressure alternately at the front of the foundation, together with a simultaneous pressure and tension alternately at the back end. Thus we see that even though an engine may be perfectly balanced in respect of its forces, it may be entirely unbalanced in respect of the couple which it exerts on the foundations due to the motion of the connecting rod. One well-known case of this is a certain central electric lighting station, where a great amount of vibration was communicated to houses 100 ft. away from the engines by the working of engines which were considered to be very well balanced in respect of forces alone. At the same time, the motion could not be detected on the foundations themselves, which were formed of a large bed of concrete. The reason assigned for the phenomenon was that the synchronous angular vibration of several large connecting rods caused the foundations to rock, a motion which could not be detected in the centre of the foundations, which point was almost at rest. The amount of motion varied, of course, as the distance from the centre of gravity of the foundations.

CHAPTER X.

BALANCING—FORCE CURVES.

WE are now in a position to find exactly the force and the couple acting on the foundations of an engine due to inertia of moving parts. For clearness sake we shall first treat of the force, leaving consideration of the couple, which, however, is quite as important, to a later chapter. Following our usual custom, we shall take a string of data from actual practice, on which to hang the explanations.

The engine (now working on board a South African liner) has a cylinder—11 in. diameter by 9 in. stroke—of high-speed vertical type, designed for heavy pressures. The calculations are worked out for a speed of 500 revolutions. The forces may be reduced to any other number (n) of revolutions by multiplying by $\left(\frac{n}{500}\right)^2$.

The following particulars of weights, &c., of moving parts will be necessary:—

Weight of piston with rings, piston rod, and crosshead with brasses = 161 lb. ;

Weight of connecting rod, with crosshead pin and brasses, 122 lb. ;

Length of connecting rod, centre to centre, 24 in. ;

Centre of gravity of rod, $8\frac{1}{2}$ in. from crank-pin centre ;

Moment of inertia of rod about centre of gravity = 59·2 lb.-ft.² ;

Weight of two cranks and pin = 73·5 lb. ;

Radius of centre of gravity of cranks and pin = 2·8 in. ;

Angular velocity of crank = $\frac{500 \times 2\pi}{60} = 52\cdot4$ radians per second ;

Centripetal acceleration of crank-pin centre = $\frac{(52\cdot4)^2 \times 4\cdot5}{12}$
 = 1030 $\frac{\text{ft.}}{\text{sec.}^2}$.

We shall plot a radial curve showing the value of the resultant force. Now, a curve drawn on a plane surface can, in the nature of things, only show the *continuous* variations of *two* mutually related variables, whereas we have three things to exhibit. It can sometimes, however, be made to do a double duty by means of explanatory figures, lines, or points marked on the curve, which show, in accordance with some given convention, not the *continuous* variation of the third variable, but its value at certain stated intervals. The contour lines marked on an ordnance map are an illustration of this. The three variables we have to exhibit are (1) position of crank, (2) magnitude of force, (3) direction of force. If the latter were always in the direction of the crank, the difficulty would disappear, but unfortunately it is not. Our method of overcoming it will appear as we proceed.

We have now to calculate the centrifugal force due to rotation of the crank shaft only. We have stated that the centrifugal force due to the rotation of any body about an axis may be calculated by finding the whole revolving weight and the distance of the centre of gravity from the axis of rotation, and using the formula $\frac{m w^2 r}{g}$, but we may often save ourselves a great deal of this work by remembering that the same result is obtained by finding the weight of only those parts which are not symmetrical about the axis. For example, if it be required to find the centrifugal force due to a straight rod turning round any point in its length, we can either find the radius of the centre of gravity of the whole and the whole weight, or (2) the centre of gravity of the unbalanced part at the end remote from the axis and the weight of that part. Thus in this case we shall obtain the same result for the centrifugal force by any of the following processes:—

(1) Take m = weight, and r = radius of centre of gravity of the whole shaft.

(2) Take m = weight of any normal section of the shaft which contains the whole of the asymmetric parts, and r = radius of the centre of gravity of that section of the shaft.

(3) Take m = weight of cranks and pin, and r = radius of centre of gravity of these parts.

Of these (3) will clearly entail least work. Hence we proceed thus:—

Weight of each crank = 28 lb.

Weight of both together = 56 lb.

Radius of their centre of gravity = $\frac{4.5 \text{ in.}}{2} = 2.25 \text{ in.}$

Weight of crank pin = 17.5 lb.

Radius of its centre of gravity = 4.5 in.

Whole weight = $56 + 17.5 = 73.5 \text{ lb.}$

Let x be the radius of its centre of gravity; then the moment of whole mass about axis = sum of moments of separate parts—that is,

$$73.5 x = 56 \times 2.25 + 17.5 \times 4.5;$$

whence $x = 2.8 \text{ in.}$

Hence, centrifugal force = $\frac{73.5 \times (52.4)^2 \times \frac{2.8}{12}}{32.2} = 1450 \text{ lb.}$

which value could also be obtained by calculating separately the centrifugal force of the cranks and pin, and adding them together.

The radius of the small circle P P in fig. 57 shows this constant value* of the centrifugal force due to the rotation of the cranks and pin, and the direction of that force, which in this case is the same as the centre line of the cranks. The small diagram on the left shows the direction in which the engine runs. The radii CP_1 , CP_2 , &c., also represent the positions of the crank, for which we shall find the other forces (due to connecting rod and piston, &c.) and the resultant

* Figs. 57–59, and nearly all subsequent figures, are carefully drawn to a scale, which is given in each case. The student should go over the calculations himself, and make drawing*, which he should compare with the given figures.

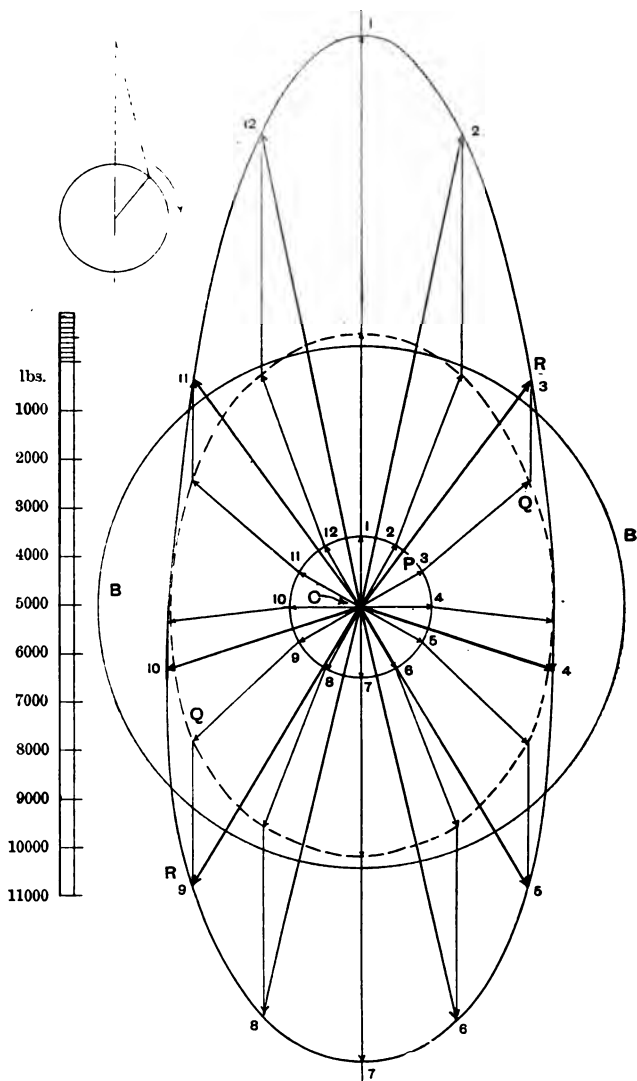

FIG. 57.—Forces acting on an engine due to inertia.
 Lines CP = centrifugal forces due to cranks and pin.
 PQ = forces due to connecting rod.
 QR = forces due to piston and rod and crosshead.
 CR = resultant.

forces. The lines Q P, joining the dotted curve to the points P, show the magnitude and direction of the forces which, acting through the centre of gravity of the connecting rod, are necessary to make that point move with the actual resultant acceleration which it has when the crank is in the corresponding position. (This acceleration is found as explained at fig. 56 in the last chapter. The force is found by multiplying the acceleration by $\frac{m}{g} = \frac{122}{32 \cdot 2}$, or, directly, by applying to fig. 56 the method indicated at the middle of page 111, *et seq.* In this case, however, it is necessary to draw separate figures for both the rod and the piston, whereas, if the acceleration only is found from the diagram, the same figure will serve for both operations.)

Conversely, the lines P Q, fig. 57, show the magnitude and direction of the reacting force which acts on the bed plate, due to the motion of the connecting rod. The vertical lines R Q show the magnitude and direction of the force necessary to accelerate or retard, as the case may be, the piston and attached parts. These forces are found as explained at fig. 47. Conversely, the lines Q R show the forces on the bed plate due to these parts.

Now, we have three forces acting independently of one another on the bed plate of the engine.

By the principle of the "polygon of forces," when any number of forces act on any body simultaneously, whatever their point of application, and these forces are represented in magnitude and direction (but not necessarily line of action) by straight lines, then the magnitude and direction (but not the point of application) of the resultant of them may be found by stringing the lines representing the forces end to end, and completing the polygon, as in C P, P Q, Q R, fig. 57. The lines C R, joining the two ends of this string, give the magnitude and direction of the resultant. Thus, when the crank is in direction C P₃, the resultant force on the bed plate is C R₃, and so on.

Now we have to consider the methods adopted for balancing these forces, as far as may be. By far the most common method is to put weights somewhere on the crank shaft, on the opposite side to the crank. These weights, in revolving, produce a *uniform* force, opposite in direction to the force CP. Now, since the resultant force CR on the bed plate is not of constant magnitude, it is clear that it cannot under any circumstances be always exactly counteracted by a force which is of constant magnitude, even though the two forces were in the same direction, which in this case they are not; so that it is evident that this method is at the best only an approximate one.

Now let us see what will be the effect of balancing by this method various fractions of the moving parts. First, suppose we have a weight or weights placed somewhere on the shaft, which, by their revolving, produce a constant force equal in magnitude and opposite in direction to the force CP, and in the same straight line. Two weights, at least, are necessary to produce this collinear effect, one on each side of the line of stroke, and whose ratio is inversely as the product of the radius of the centre of gravity of each weight, and its distance from the line of stroke measured in front elevation. One weight—*e.g.*, on the flywheel—might produce a force equal in magnitude and opposite in direction, but it obviously could not be in the same straight line—*i.e.*, the line of stroke. We shall treat this question more fully when we come to the subject of couples.

The effect is obviously the same as if the circle PP in fig. 57 had dwindled to a point, and the large elliptical curve in fig. 58 shows the result, which is simply the forces PQ, QR plotted in series radially, and a curve drawn through the points R. The figures refer to the corresponding positions of the crank, as shown in fig. 57. The resultant forces, under these conditions, are found by joining the centre to any of the points on the large elliptical curve. Now, if more weight than this had been balanced, the radius of the circle PP, fig. 57, would, as it were, pass through zero to a negative quantity. Let CB,

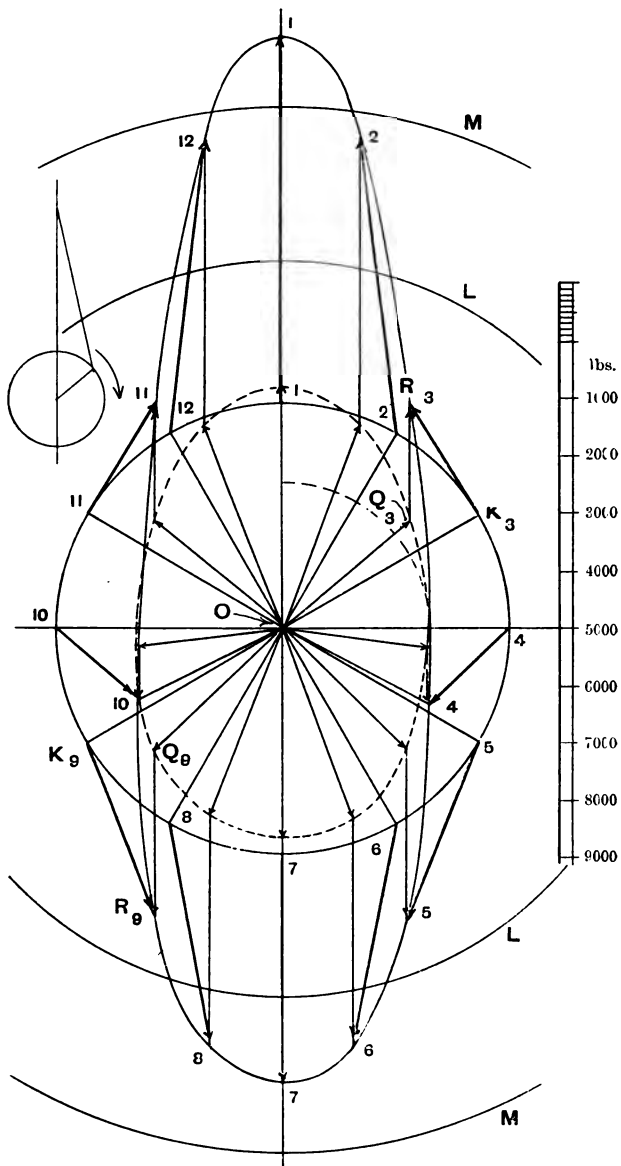

FIG. 58.

Radii of curve RR = forces on an engine due to inertia with cranks and pin balanced.

Radii of curve QQ = forces on connecting rod.

fig. 57, be the radius of the balance circle—that is, it represents the *total* force due to the balance weight, which force acts in the opposite direction to C P. It is clear that the resultant of the two opposite forces will be represented by the difference of the radii, and since this difference is constant, the resultant curve will be a circle. If C B is less than C P, the effect will be to reduce the radius of circle P P by the amount C B. We have already discussed the case when $C B = C P$. The radius of the resultant circle will be negative when $C B > C P$. We have then finally to find the resultant of two resultants, which are respectively represented by $C B - C P$, and the line joining C, in fig. 58, to the corresponding point of the elliptical curve. Now, the actual circle B, shown in fig. 57, has for its radius the force due to a balance weight which balances both the cranks and pin, and the whole of the connecting rod, which latter is supposed concentrated at the centre of the crank pin; and the radius of the complete circle K K, in fig. 58, represents the difference between the radii of the two circles B B and P P, in fig. 57.

When the crank is at K_3 , fig. 58, the resultant balancing force represented by the radius of K K is $K_3 O$ in magnitude and direction, and to find the magnitude and direction of the resultant of $K_3 O$, $O Q_3$, $Q_3 R_3$, we have merely to join $K_3 R_3$. $K_3 R_3$ then represents this force.

In actual practice we should dispense with fig. 58 altogether, and obtain the forces by joining points on such circles as B B, fig. 57, with the corresponding points on the outer elliptical figure. It will be seen that this will give the same result as the other construction.

The next process is to take all such lines as $K_3 R_3$ out of fig. 58, or the corresponding ones out of fig. 57, and plot them in magnitude and direction round a separate point S, taking care to number them so that they may be recognised. This produces curve A, in fig. 59.

Now, to investigate the effect of increasing still further the balance weight, we have merely to increase the radius of circle K K, in fig. 58, and, proceeding exactly as before,

plot the result round S, fig. 59. Circle L, fig. 58, and curve B, fig. 59, represent the result of balancing the cranks and pin together with a force half way between the maximum and minimum forces produced by the moving parts, as obtained from fig. 58. Circle M and curve C represent the result of

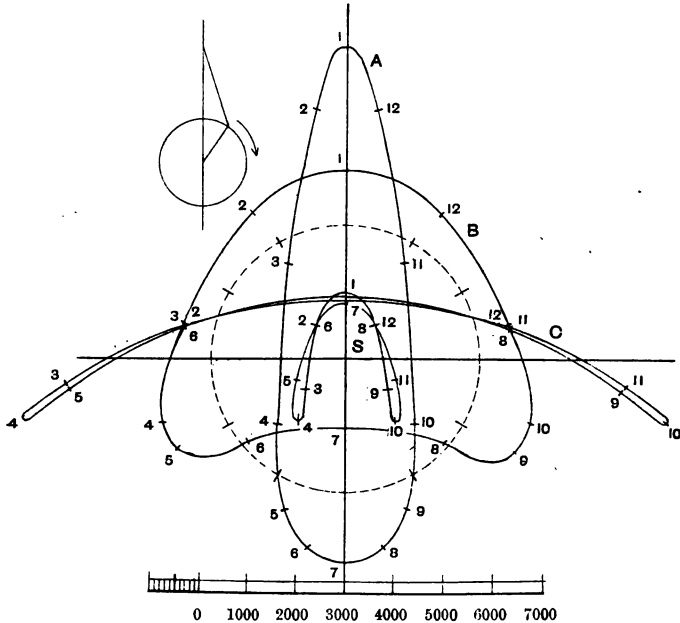

FIG. 59.—Forces acting on the bed plate of a single engine when the following portions of the moving parts are balanced: Curve A. Cranks, pin, and connecting rod. B. Cranks and pin + $\frac{\text{max.} + \text{min.}}{2}$ of forces on fig. 58. C. The whole of the moving parts.

balancing the whole of the rotating and reciprocating parts. Notice the elegant way in which the curve changes as the balance weight is increased, from a sort of oval to a twice-traced circular arc. It is also extremely interesting from a mathematical point of view to carry the process still further,

but it has nothing to do with engineering, because engines are never overbalanced in this way—unless the balance weights are put in “by eye,” a method not unknown in modern engineering. It must be clearly understood that the numbers are an essential part of these curves, fig. 59. When the crank is at 6, the resultant force is S 6, fig. 59, and so on.

Now, the fraction of the total weight which is to be balanced must depend entirely on the character of engine and foundations. When accuracy is required, no rules of thumb can do more than give a haphazard result. They may do very well for stationary engines, bolted to tremendous foundations with enormous bolts. Common sense must be brought into play in determining which is the best curve to use. Thus, in a vertical engine on a carriage resting on springs, suppose, changes of vertical force on the springs must be avoided as far as possible; in other words, balance the whole of the weight, or, at anyrate, a large part of it; otherwise dangerous oscillations may be set up in the springs when the revolutions of the engine synchronise with the natural period of oscillation of the loaded spring.

In a locomotive (which will be subsequently dealt with) it is also the practice to balance a large part of the weight, because changes of vertical force such as will be produced by the action of such forces as S 11c, in fig. 59, mainly tend to lift or intensify that part of the great weight of the engine which comes upon the wheels on which the balance weights are put; and so long as this force is not so great as to lift the wheels off the rails, it is, comparatively speaking, unimportant, producing merely extra wear on those parts of the tyres which are on the same side of the wheel as the balance weight, whereas great horizontal forces produce dangerous couples in a horizontal plane, which tend to twist the engine off the rails. This part of the subject will be treated later. Now, curve B, fig. 59, represents perhaps the best all-round balancing that can be adopted, because here the vertical and horizontal forces are somewhere about equal; so that here the

maximum force produced is a minimum. It will be seen that at the best it is very far indeed from perfection. The minimum maximum force is close on 4,000 lb. Curve B, fig. 59, suggests a peculiar method of improving the balance which, so far as the author has been able to ascertain, has never been previously proposed, and which is interesting, although perhaps impracticable. It will be observed that the points on curve B go the opposite way round to the points on the crank circle, and further, that, roughly speaking, the angle between any two successive radii is constant. If, then, we arrange an auxiliary balance weight on the crank shaft, and gear it by means of three bevel wheels, the middle one of which is fixed to the bed plate so that the auxiliary balance wheel goes the opposite way round to the direction of the crank shaft with equal angular velocity, and being so placed that it is on the same side of the crank shaft as the primary balance weight at either dead centre, the balance will, if the weight be judiciously chosen, be very much improved. The dotted circle in fig. 59 represents the effect of a reverse balance weight of 86 lb. at a radius equal to that of the crank-pin centre, combined with the primary weight necessary to produce curve B. The small curve in the centre shows the effect of this device. The curve is obviously a great improvement on any of the other curves, showing, as it does, a reduction of the maximum force from 4,000 lb. to 1,500.

CHAPTER XI.

METHODS OF FORCE BALANCING.

THE balance circle having been decided upon, and drawn on fig. 57, it remains to deduce the corresponding position and magnitude of the balance weights. To do this, measure the radius of the selected circle on fig. 57 by the force scale.

Suppose this radius represents 7,900 lb., signifying that this is the *total* force due to the rotation of the balance weights.

Suppose also that, pending further discussion as to couples, we have decided to use two balance weights, so proportioned as to bring the resultant force due to them into the central plane of the engine.

First suppose that the centre of gravity of each of the two balance weights is at the same distance r feet from the axis, the sum of the weights being M .

Then we have

$$\frac{M w^2 r}{32 \cdot 2} = 7900 ;$$

that is, the product of the sum of the two weights into their radius

$$= M r = \frac{32 \cdot 2 \times 7900}{w^2} = 93 \text{ pounds-feet.}$$

Hence, the larger the radius, the smaller may the weights be, and *vice versa*, the product of the two being always 93.

The reason for using two balance weights instead of a single one is that a force acting in one plane cannot be counteracted by an opposite force acting in another. If two forces equal in magnitude and opposite in direction act on a body, not being in the same straight line, they produce together a couple, or tendency to twist the body about any line perpendicular to the plane containing the two forces. Now, if we attempt to balance the force due to inertia (which always acts in the central plane of the engine) by one weight on one flywheel, which cannot, of course, be in the central plane, we produce this effect, which will be further treated of later on. Hence we are driven to dividing the weight into two parts, which must be so disposed that the resultant force due to them lies in the central plane. This can be done in two ways. Let RR_1 , fig. 60, be the trace of the central plane of the engine, and AB , CD the planes in which the balance weights work.

Take any line AC parallel to the shaft, set off AK equal to the radius of the balance circle (or, if the two radii of the balance weights are to be equal, take AK equal to the total weight, already deduced, to scale); join KC , and draw the line D_1B_1 through R parallel to KC ; then AD_1 will give the magnitude of the force acting at C (notice the reversal AD_1 acts at C , and not at A), and CB_1 that acting at A (or, in the alternative given in brackets above, AD_1 and CB_1 give the actual weights to be placed on the wheels). It will be seen that it is not correct to make the centre of

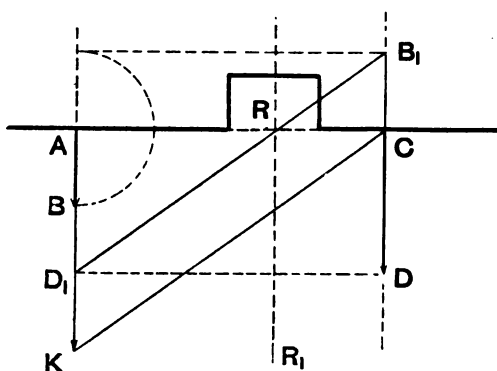

FIG. 60.

gravity of the two weights lie in the central plane unless the radii are equal. If they are unequal, each weight must be calculated from the force found as in fig. 60. These weights are usually cast on the flywheels. If it is impossible to have a balance weight on each side of the crank pin, the following method will do instead, if it can be managed without undue increase of weight. Use two flywheels, which may or may not be joined together, with one large weight in plane AB_1 fig. 61, opposite the crank, and an outer smaller one in plane CD , the latter being at the opposite end of the diameter to the weight B —that is, on the

same side as the crank seen in side elevation. The difference between the forces produced by these weights must be equal to the radius of the balance circle. In order to find these forces (or, as before, if the radii are equal, the weights), set off CK , fig. 61, equal to the radius of the balance circle (or the net calculated weight). Join AK and draw RB_1 parallel. Then CB_1 gives the force on the *inner*

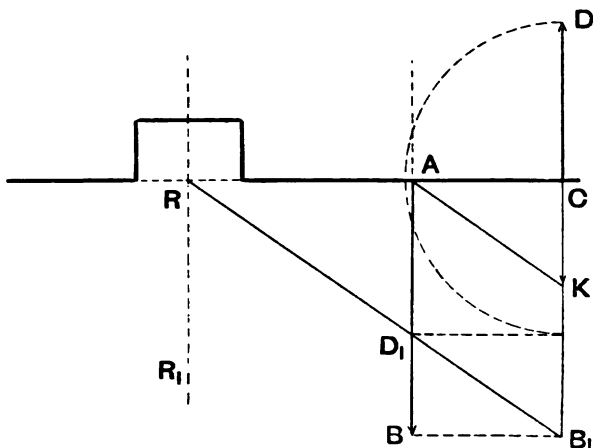

FIG. 61.

wheel, and AD_1 the opposite force on the *outer*, the resultant of the two forces acting at R . There seems no reason why this method should not be adopted in cases where the moving parts are light, and good balance is required. The weights could easily be cast on the opposite sides of a broad flywheel, which it would no doubt make somewhat heavy, but it would certainly be much cheaper than the next method we shall explain, which is usually accounted the best system of balancing by rotating weights. It must not be forgotten that any method of balancing by balance weights involves an increase or decrease of the bending moment on the shaft, which

ought to be taken count of in accurate design, especially where the revolutions are high. The method has been already explained in the articles on crank shafts.

BALANCED CRANKS.

By this method the cranks are continued to the other side of the shaft, and spread out so as to give a large weight, as shown in fig. 62. This weight constitutes the balance weight. In small engines it may conveniently be made of the shape shown dotted, for cheapness' sake. The edges can then be planed or milled at one setting. At the best, however, it is very expensive and tedious to make. The numerical calculation of the shape of this weight is by no means an easy matter. The following geometrico-mechanical one is an easy method to use. Calculate, as in

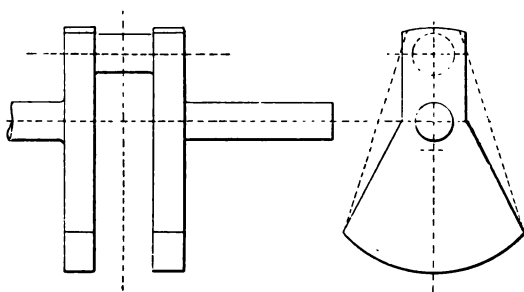

FIG. 62.

fig. 58 (not fig. 57), the magnitude of the balance weight corresponding to a radius equal to the crank radius. The weight of the rotating parts (*i.e.*, the cranks and pin) must be left out in this calculation.

Draw an end view (full size, if possible) of the cranks on a large piece of stout white cardboard, of uniform thickness, dotting in the shaft and the crank pin, as shown in fig. 63. Determine the greatest reasonable radius which the balance weight can have so as not to foul the bed plate, and draw the

arc AB to this radius.* In determining this radius, regard must be paid to the fact that the larger the radius the more expensive per unit weight the shaft is to make, since all the steel between the cranks has to be sawn, drilled, or slotted out; and if the radius is very large, the turning of the crank pin is a very awkward task. Take care to make the arc AB longer than can possibly be required, and

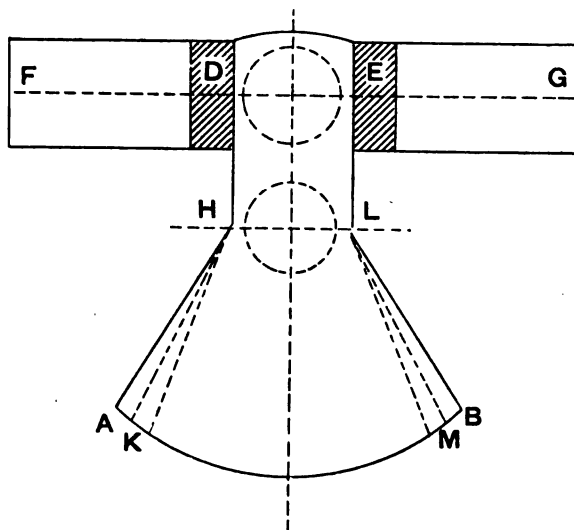

FIG. 63.

symmetrical about the centre line. Draw a line FG through the crank-pin centre. Now, the area or weight of this cardboard is to represent the weight of both cranks together.

* To minimise the expense of machining, it is often advisable to turn up the top and bottom of the crank from the same centre, below the centre of the shaft, as in fig. 62. The balance weight looks better when working if the bottom is central with the shaft, as in fig. 63. The top may then be planed or shaped lengthways by special tackle, or they may be done in the lathe off lower centres, or by "reversing."

Suppose the thickness of each crank in front elevation is $2\frac{1}{2}$ in. One square inch of cardboard then represents 5 cubic inches of steel,

$$= 5 \times 0.28 = 1.4 \text{ lb.}$$

Next calculate the cubic contents of the crank pin and its weight. Suppose this latter is 17.5 lb. It is then represented by

$$\frac{17.5}{1.4} = 12.5$$

square inches of cardboard. Mark off on each side of the crank pin the hatched areas D, E (each of which is 6.25 square inches) in such a way that the centre of gravity of the two coincides with the crank-pin centre. Next take the magnitude of the weight already found, balancing the connecting rod and reciprocating parts at a radius equal to the crank radius, and, dividing the corresponding area into two equal parts, draw them at F and G so that their centre of gravity coincides with the crank-pin centre. Next cut the whole figure out with a sharp knife. Stick a pin through the centre of the shaft, and try the balance of the figure. The side A B should be the heavier. If it is not, then another piece of cardboard must be cut out, so that the side A B is heavier. Next mark off a series of lines in pairs, H K, L M, as shown, each pair of which is equidistant from the centre line. Cut off the thin triangular pieces, K A H, M B L, in pairs, so as to keep the figure always symmetrical about the centre line, until a perfect balance is obtained about the centre of the shaft. When this is the case, the figure K M L E D H shows the exact size of the required cranks.

OTHER METHODS.

There are several other methods of balancing the forces called into play by inertia. They all involve additional parts, so linked to the piston that when that member moves in any direction the balance weights move in the opposite one. In marine engines, for instance, the air-pump bucket

tends to balance the low-pressure piston, to which it is attached.

Mr. Yarrow, in his torpedo-destroyer engines, which run at very high speeds, introduced a system of what he calls bobweights, which are weights lifted and depressed by the action of eccentrics on the shaft, placed in such positions that the centre of gravity of the whole engine does not move when the engine works. When this condition is perfectly fulfilled there is always perfect force balance, but not necessarily perfect couple balance, this latter being due

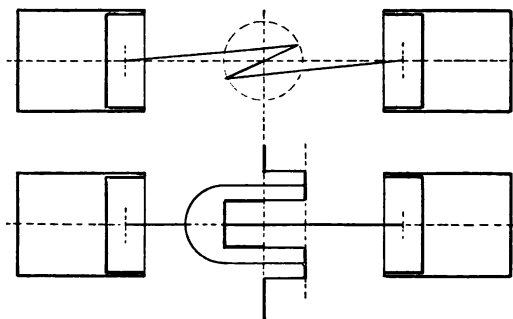

FIG. 64.

to the fact that the lines which are the angular analogue of the centre of gravity do not necessarily remain at rest, although the centre of gravity does. It can also be proved that a perfect balance can be obtained by means of six sets of details on the same side of the crank shaft with cranks judiciously arranged. This proof is rather too complicated for these articles.

There is one other method which, from its simplicity, is worthy of mention. By its means an absolutely perfect force balance is obtained. If properly designed on this principle, an engine will run without a trace of vibration.

It will have been noticed that a difficulty in obtaining perfect balance arises from the fact that the acceleration of the piston, &c., is not the same at both ends of the stroke.

If it were not for this fact, the method of reversed counterweights, similar to that described on page 137, could be arranged to give a practically perfect balance. It is fundamentally dependent on the peculiar motion of the connecting rod. The remedy is therefore to balance the connecting rod by another one, moving in precisely the same manner in an opposite direction—that is, have two cylinders at opposite sides of the same crank shaft, working on cranks opposite, as in fig. 64, so that the connecting rods (one of which is deeply forked, as shown) are of the same weight, and have the same moment of inertia about a transverse axis through the centre of gravity of the rod and parallel to the crank pin. The pistons, with their attachments, must weigh the same, and the crank shaft must have its centre of gravity lying in the axis of rotation, which axis must also be a principal axis. If these considerations were all attended to, perfect force balance would be the result, though *there will be a slight want of couple balance*, due to the fact that the forces due to the connecting rods, though always parallel, are not collinear.

CHAPTER XII.

THE THEORY OF COUPLES.

WHEN all the forces acting from outside on any body (which for clearness we may imagine as floating in mid space, so as to be perfectly free to move in any direction) have a resultant whose line of action does not pass through the centre of gravity of the body, the effect on that body is the same as if a parallel force of equal magnitude were acting on the centre of gravity of the body, and at the same time a couple tending to turn the body round, whose magnitude is equal to the product of the force into the perpendicular distance of the centre of gravity from the line of action. Thus, suppose the body sketched in fig. 65, whose mass is m

pounds, and whose centre of gravity is at G, in the plane of the paper, is acted on by a resultant force R pounds weight, also in the plane of the paper. As has been already stated, the result will be an acceleration of the centre of gravity of magnitude $\frac{Rg}{m}$ in direction R.

Now, owing to the inertia of the body, every part of the body tends to lag behind. All the forces due to this lagging tendency have a resultant which, in all positions of the body, passes through the point G. We may, therefore, consider that all the mass of the body is concentrated at G, which point is endowed with all the mass of the whole body, the rest of the body being, for present purposes, devoid of mass or inertia. The point G is called the "centre of gravity," but would be better called the

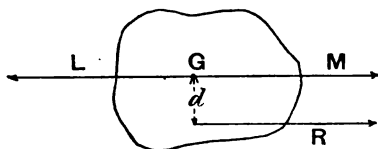

FIG. 65.

"centre of mass," for the actual centre of gravity only absolutely coincides with the centre of mass in special cases, although in all practical cases it is extremely near to it. The force with which the point G, as representing the whole body, tends to lag forms a complete balance to all the external forces acting upon the body, and is therefore equal to $\frac{ma}{g}$, or R. That is to say,

there is always exact equilibrium between all the external forces acting on any body, including this lagging force. There is, in fact, no such thing as an unbalanced force in the universe, because the nature of matter is such that a balancing lag force is always instantaneously generated by the mass itself on which the forces act. There can be in

the nature of things no such manifestation as force unless there is also a mass for the force to act upon. All this is implied in the assertion that "matter has inertia."

In this case the force R and the lag force together constitute a couple of magnitude Rd pounds-feet, which gives the body an angular acceleration of $\frac{Rgd}{I}$ radians per second

per second, and there is in the same way a lag couple called into existence by the angular acceleration, which forms a complete balance to all external couples, the lag force being only called into existence when the body has the linear acceleration a . Hence the effect of the force R is the same as that of an equal force acting at the centre of gravity, which, *per se*, would produce the linear acceleration a , and a couple, which would *independently* produce the angular acceleration, combined. This proposition is usually proved in the following way: The state of rest or motion of G will not be altered by introducing two equal and opposite forces L, M , acting at that point, each equal to R . L and R constitute a couple, and M the accelerating force.

This appears a somewhat lifeless and unsatisfactory explanation, as it leaves out of count the real though passive lagging force, while introducing two forces that are not wanted, and are, in fact, non-existent. There is, of course, no energy gained by making the force act away from the centre of gravity, for although the energy due to the action of the force is greater than would have been the case if the force had acted *for the same time* on the centre of gravity by an amount equal to the rotational energy, yet the additional rotational energy is exactly compensated for by the greater distance through which the point of application of R has to move, due to the rotation, than would have been the case had the force acted through the centre of gravity. Now, since a couple has no point of application, but has the same pure twisting effect on the motion of the body as another couple of equal moment acting in a parallel plane, it is clear that we may make a line perpendicular

to the plane completely represent the couple, for the length of the line may represent the magnitude, or "moment," of the couple to scale, while the direction of the line shows not only the direction of the axis round which the couple it represents tends to twist the body, but also by convention the arrow head on the line may indicate the direction as regards right or left handed rotation in which the couple tends to twist the body.

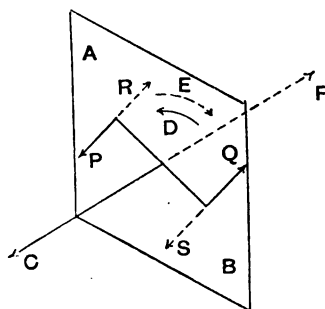

FIG. 66.

This convention is as follows: The direction of the arrow shows the direction in which a right-handed screw would move due to the rotation produced by the couple. If the direction be the same as the hands of a clock, the screw will move towards the back of the clock, and *vice versa*. Thus the couple PQ lying in plane AB, shown in perspective in fig. 66 (both forces of which are supposed to be acting simultaneously on some body not shown, but of which AB is a plane section), is represented by any line C perpendicular to plane AB, whereas a couple RS, in the direction E, shown dotted, would be represented by any line parallel to F.

Now, we shall prove that when couples are represented in this way they may be compounded by the parallelogram law. Thus, in fig. 67, the couple PQ acts on a body in

plane AB , and the couple RS simultaneously on the same body in plane CD . Then these couples are respectively represented in plan by Op and Or . We shall prove that their resultant is Ox , acting in plane MN (shown dotted in the perspective view), at XY .

The formal proof of this proposition is briefly as follows: The couple PQ of fig. 67 has precisely the same pure

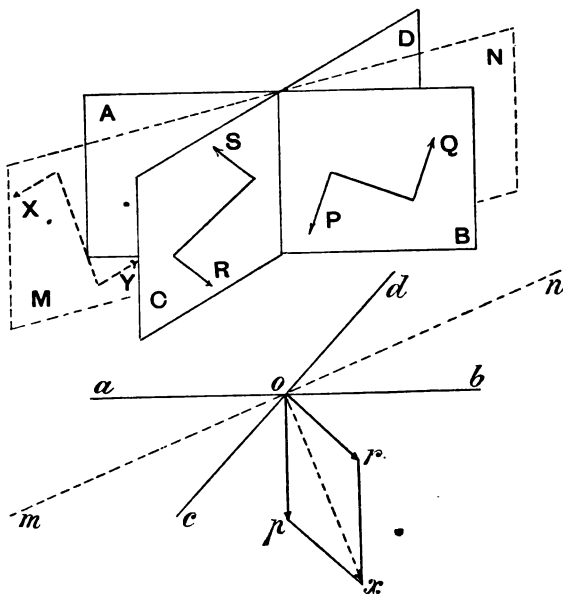

FIG. 67.—Perspective View and Plan.

twisting effect on the body on which it acts as a couple of equal moment pq in fig. 67A. (This may easily be proved by showing that if PQ of fig. 67 acts on a body simultaneously with any couple whose forces are equal in

magnitude but opposite in direction to those of $p q$, in fig. 67A, then all the component forces will be in equilibrium.) Similarly couple $R S$ of fig. 67 = $r s$ of fig. 67A. Now, forces $h p$ and $h r$ in planes $a b$, $c d$ respectively have a resultant $h x$ in plane $m n$, and $k s$ and $k g$ have a resultant $k y$. From symmetry $h x$ and $k y$ are equal, parallel, and opposite, and are in the same plane $m n$, passing through

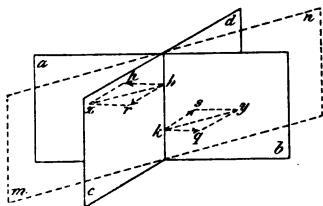

FIG. 67A.

the intersection of planes $a b$ and $c d$. Hence the resultant of any two couples $p q$ and $r s$ is a couple $x y$. Now, the arms of all these three couples are the same line $h k$. Hence the moments of the couples are respectively proportional to the forces that compose them. Hence it is obvious that since $O p$, $O r$ of fig. 67 are respectively proportional to forces $h p$, $h r$ of fig. 67A, and are perpendicular to planes $a b$, $c d$, therefore $O x$ will be proportional to force $h x$ and perpendicular to plane $m n$, and will therefore represent the couple $x y$ (which, of course, = $X Y$) to the same scale as $O p$, $O r$ represent couples $p q$, $r s$.

Now, any set of forces and any set of couples acting on a body are most conveniently examined and clearly represented by taking their components in three definite directions, mutually perpendicular. In a machine there are usually three main centre lines, mutually perpendicular. We shall take these as our axes.

Bearing in mind this proposition of the resolution and composition of couples, the following principles show how

to estimate the couple acting in any plane on a body, due to a force. Suppose a force R pounds, represented by PR , the line representing which is shown in three views in fig. 68, and which is parallel to planes 1 and 3, acts on the body

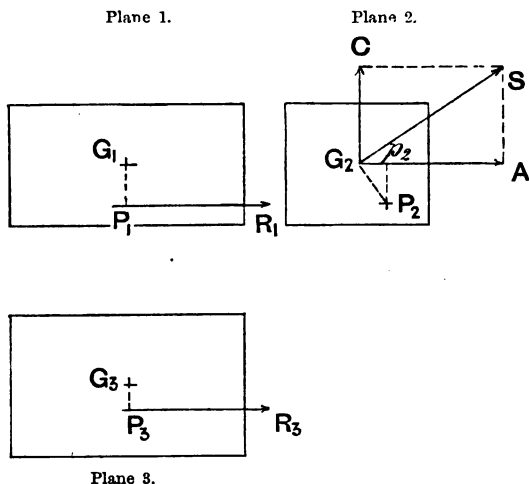

FIG. 68.

shown (whose centre of gravity is G) at point P . The total resultant couple which this force produces is clearly

$$R \times P_2 G_2,$$

for $P_2 G_2$ is the total perpendicular distance of G from the line of the force. This couple is represented by $G_2 S$, which

$$= R \times G_2 P_2,$$

and which is seen full length in plane 2. Couple $G_2 S$ may be resolved into two couples, $G_2 A$ and $G_2 C$. Of these, $G_2 A$ is the component which acts in plane 1, and $G_2 C$ in plane 3. We are about to prove that the component

$$\begin{aligned} G_2 A &= P_1 R_1 \times G_1 P_1 \\ G_2 C &= P_3 R_3 \times G_3 P_3. \end{aligned}$$

Now,

$$\frac{G_2 A}{G_2 S} = \frac{P_2 p_2}{G_2 P_2} = \frac{G_1 P_1}{G_2 P_2};$$

therefore, multiplying up,

$$G_2 A = \frac{G_2 S \times G_1 P_1}{G_2 P_2};$$

also,

$$G_2 S = R \times G_2 P_2;$$

whence, substituting,

$$G_2 A = R \times G_1 P_1.$$

Expressed verbally, this result is as follows :—

1. When a force (R), the line representing which is seen full length in any view (1) of a body without any foreshortening, then the component ($G_2 A$) of the couple due to the force which acts in that plane (1) is equal to the product of the force into the projection ($G_1 P_1$) on that plane of the total perpendicular distance ($G_2 P_2$) of the centre of gravity from the line of action of the force.

But we may go further than this. Let any oblique force PR, fig. 69, whose components in the three standard directions are shown at $P_1 p_1$, $P_2 p_2$, $P_3 p_3$, and whose total magnitude is PR, obtained as shown in the figure on the right, and whose projected lengths in the three views are respectively $P_1 R_1$, $P_2 R_2$, $P_3 R_2$, act upon the body. We shall show that the couple in plane 1 is

$$P_1 R_1 \times G_1 g_1,$$

and similarly for the other planes.

Now, the force PR will have precisely the same kinematical effect on the body as its three components $P_1 p_1$, $P_2 p_2$, $P_3 p_3$. Of these, $P_2 p_2$ can produce no couple in plane 1, for it is perpendicular to that plane, and the total couple effect in plane 1 is therefore that due to forces $P_1 p_1$, $P_3 p_3$. Now, the effect of these is precisely the same as that of their resultant, $P_1 R_1$, both as regards force and moment

about any point (see Hicks, page 111). As we have already shown at 1 above, the couple effect of $P_1 R_1$, since it is seen full length in plane 1, will be

$$P_1 R_1 \times G_1 g_1.$$

Hence we have the general proposition :

2. To find the couple due to any force whatever, in any plane, take the projected length of the force on

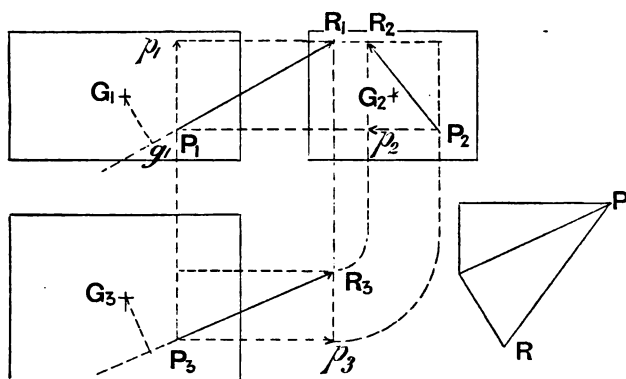

FIG. 69.

that plane, and the projected distance of the centre of gravity from the projection of the line of action of the force, and multiply them together.

EFFECT OF TWO FORCES.

When there are two forces not in the same plane acting on a body, their kinematical effect is the same as that of a resultant force and a resultant couple, the magnitude of each of which can be easily found. Consider the forces PQ, RS , represented in fig. 70 as acting one in each of two planes, both parallel to the plane of the paper. The traces of

these planes are seen in the plan. And it may here be remarked that two parallel planes can always be drawn, each containing one of any two lines in space ; for a plane

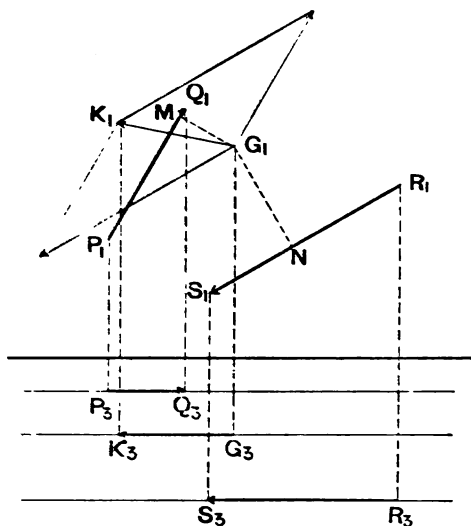

FIG. 70.

containing one of the lines can always be rotated round that line as axis till it is parallel to the other line, so that this investigation is perfectly general for any two forces whatever acting on a body.

Now, each of these two forces will produce its own effect on the motion of the centre of gravity G , and its own particular set of couples, independently of the other. The translational effect of each force has been shown to be that of a parallel force acting through the centre of gravity. Hence the resultant translational effect will be that of force $G_1 K_1$. The couples will be determined exactly as before, thus—

Couple acting in plane 1

$$= P_1 Q_1 \times G_1 M + R_1 S_1 \times G_1 N,$$

and so on. Continuing this reasoning on for three or more forces, the same theorem can be made perfectly general, and, if all the forces are correctly represented in the three projections, the estimation of the resultant forces and couples is quite easy. It is impossible to understand the problem of balancing thoroughly, unless these principles are fully understood.

CHAPTER XIII.

INERTIA COUPLES ON AN ENGINE.

Now, the forces on an engine due to inertia act only in one or more parallel planes—the central planes of the cylinders.

The whole of the *forces* can therefore be set off on one diagram representing that plane, as we have done. In the case of couples, however, this is not so. The resultant couples act in every conceivable plane. They have varying components in each of the three planes of reference, which we shall have to consider separately.

SINGLE HORIZONTAL ENGINE.

Consider, first, a single horizontal stationary engine, whose details are the same as those given above. We shall take the couples in the various planes in the following order:—

1. Those acting in or parallel to the central plane as seen in side elevation, the lines representing which are parallel to the crank shaft.
2. The plane seen in end elevation, represented by lines parallel to the axis of the cylinder.
- 3 The plane seen in the plan, represented by vertical lines.

The balance of engines of this type is not a matter of very great importance, as they are usually bolted to very heavy foundations, so we shall treat of them as briefly as possible, showing how the couples arise and how they may be measured.

The lines representing the couples in each plane are seen full length in each of the other two views. Suppose, first, that the engine is balanced by two counterweights, as already explained, so adjusted as to bring the resultant force due to them into the central plane of the engine.

1. The couples in this plane are due to three causes:—

- (a) Angular acceleration of flywheel and rotating parts.
- (b) Angular acceleration of the connecting rod.
- (c) The fact that the line of action of the unbalanced force does not pass through the centre of gravity of the engine and foundations taken together, when these are considered as separate from the ground in which the foundations are embedded.

Of these (a) is small, and therefore unimportant, but could be found by the help of the principles explained under "Flywheels."

(b) can be found by the method explained in Chapter IX. The curve deduced by this method will be given shortly (fig. 78) when considering a two-cylinder engine.

(c) can be found, if the centre of gravity of the foundation be known, by finding the line of action of each of the forces by the following construction, and multiplying the force into the perpendicular distance of the centre of gravity from this line. Q, fig. 71, being the crank-pin centre, make the construction of fig. 56, and find CT, the force due to the piston, &c. Take CD equal to the force due to the balance weight, less that due to the cranks and pin, and find the resultant CR of CT and CD. Take GK, the line of action of the force on the connecting rod, and produce it till it meets CR in E. Mark off at EF on EG the force due to the connecting rod, and find the resultant ES acting

through E of EF and force EH, which = CR. This resultant gives the line of action required.

2. Couples in this plane only exist when the centre of gravity of the foundations is not in the central plane of the engine. They are equal to the product of the distance between the centre of gravity and the central plane into the vertical component of the unbalanced force. The first factor

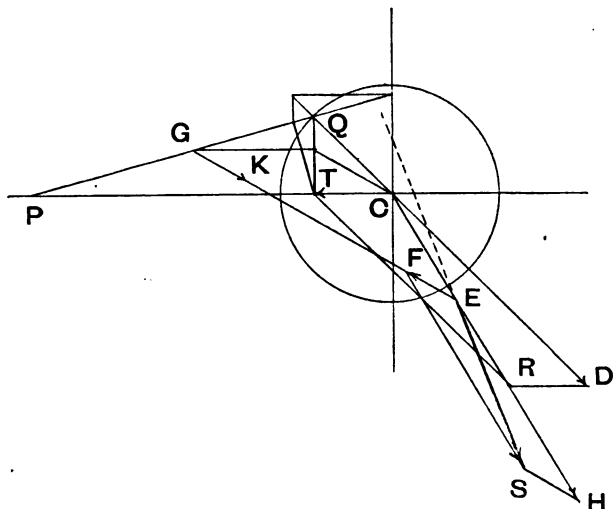

FIG. 71.—Construction for finding line of action of resultant force.

of this product being constant, the variations of the second factor show the variations of the couple.

3. The same remark applies to these couples, the product in this case being that of the same distance as before with the horizontal component of the unbalanced force.

When there is only one balance weight on the flywheel, 1 is the same as before, as the alteration does not affect couples in this plane. In the case of 2 and 3, however, an additional couple is produced, which is represented in each case by radial

curves, which, when developed on to a straight line, become harmonic curves, and which, therefore, radially are pairs of circles whose diameters are vertical and horizontal respectively, and of a magnitude representing the product of the force due to the balance weight, and the distance in end elevation from the centre of gravity of the weight to the central plane. These curves are shown in fig. 72. Thus when the crank is in position OP_2 , OP_3 , the couple in plane 2 is OR_2 , and in plane 3, OR_3 .

It is a matter of opinion to what extent this method of balancing is better or worse than no balancing at all—that is to say, whether the vibrations and other effects produced

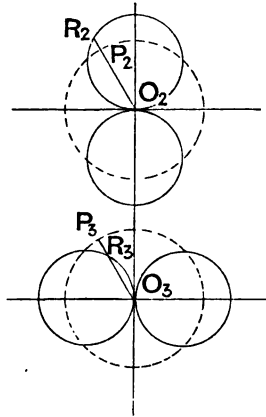

FIG. 72.—Curves showing the nature of the couple disturbance due to one balance weight only.

by this couple, whose axis continually rotates at 90 deg. in front of or behind the balance weight, according as the flywheel is on the left or right of the engine as seen from behind, be not more prejudicial to smooth running than the forces which the weight is supposed to balance. As far as regards the vibration, it, of course, depends to a large extent on the distance between the flywheel and

the central plane, but in any case the rotation of the weight produces additional stresses in the shaft and wear of the bearing, so that it is certainly open to question whether it be not better dynamically to leave an engine unbalanced altogether. With vertical engines, however, the weight of moving parts is so great, that not only does it produce an appreciable difference in speed between the upstroke and the downstroke (especially in slow-moving engines), owing to, on the one hand, the extra work that has to be done by the steam in lifting the parts, and, on the other, the additional work that is done by descent of the parts themselves on the downstroke, the amount of work being, in fact, drawn from the steam during the upstroke and carried forward to the downstroke; but, in addition, the weight is so disposed that the engine always stops on the bottom dead centre, making the engine difficult to start, especially when cut-off takes place early. For these reasons it is well to balance a large part of the weight of moving parts of vertical engines, even when only one balance weight can be used, especially when they have to be frequently stopped.

We shall now apply the principles enunciated in the last chapter to the drawing of diagrams for two-cylinder engines, with cranks (1) opposite, (2) at right angles, in order to exhibit exactly the nature of the disturbance due to inertia. We shall not treat of three-cylinder engines, because, if the principles here explained are thoroughly understood, the student will have no difficulty in doing it for himself, and, if they are not, nothing we can say short of reiteration will help him.

TWO-CYLINDER ENGINES.

(1) CRANKS OPPOSITE.

We shall first derive the force curve for a vertical engine with two equal cylinders, and whose details are the same as previously given, and whose central planes are 18 in. apart. This curve is seen in fig. 73, which curve is twice traced,

as shown by the numbers on the curve, these numbers referring to the position of crank pin No. 1. This is due to the fact that during the second half of the revolution the forces due to the piston and connecting rod, &c., of cylinder No. 2 are precisely identical with those due to the parts of cylinder 1 during the first half, and *vice versa*. Therefore the resultant force when the pin 1 is in position 3, suppose, is the same as when pin 2 is at 3—that is, when pin 1 is at 9. Hence 3 and 9 on the curve are the same point.

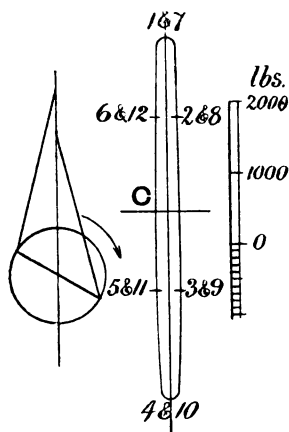

FIG. 73.—Inertia forces acting on a two-cylinder engine with cranks opposite.

Fig. 73 is obtained by combining on fig. 57 force 1 with 7, 2 with 8, and so on, by means of the parallelogram of forces. It has been remarked that this is a favourite form for high-speed engines, and a comparison of fig. 72 with fig. 57 (which latter represents the force curve for one of the cylinders) will explain the reason. It must be borne in mind that fig. 73 is produced without any balance weights at all, the result being due to the fact that when one piston, &c., is being accelerated in one direction, the other is being accelerated in the opposite one, except for a certain small distance near

mid-stroke, during which the accelerations are in the same direction. Owing, however, to the effect of obliquity, these accelerations are not always exactly equal, otherwise curve 73 would reduce to a point; in other words, force balance would be perfect.

It is quite another matter, however, with the couple balance, since the opposite forces are not in the same straight line. Consider first couples parallel to plane 1, the central plane.

The couples in this plane are due to three causes, explained in the last section, page 156.

(a) is found precisely as there explained, except that, there being two tangential forces which vanish at the same instant—*i.e.*, at dead centres—the resultant variation of angular velocity of the flywheel is almost double of what it is with one cylinder only. In spite of this, however, it is small compared to the other couples, and therefore unimportant.

(b) The couples due to the angular acceleration of the connecting rods will be given in the next chapter, fig. 82. It will be there seen that at opposite points of the crank circle the angular accelerations of the rods are practically equal and opposite, and therefore, the rods being precisely alike, the resultant couple due to both rods together vanishes.

(c) There being little force in plane 1, the couple due to the fact that it does not pass through the centre of gravity will be small, and therefore unimportant.

Thus it appears that with engines of this type couples in plane 1 practically disappear.

Plane 2.—The couples in this plane—the front elevation—whose axes are horizontal, and from front to back of the engine, or *vice versa*, and which tend to overturn the engine sideways, are found as follows: The oval curve in fig. 74 represents the forces acting on a single engine; being, in fact, a reduced copy of fig. 57. Consider the instant when crank pin A is at 5, as shown. The

position of the cranks is referred to that of one pin A, to avoid confusion. It is clear that, at this point of the stroke, force O 5 is acting in plane A, and O 11 in plane B. Now, it follows from what we have said that it is the vertical component only of these forces which produces couples in plane 2; that is to say, the couple at this instant is that produced by forces $A_2 P_2$, $B_2 Q_2$. The magnitude of this couple is clearly

$$A_2 P_2 \times \frac{d}{2} + B_2 Q_2 \times \frac{d}{2} = (A_2 P_2 + B_2 Q_2) \times \frac{d}{2}.$$

Since $\frac{d}{2}$ is constant, it is clear that the required couple is represented to some scale or other by $(A_2 P_2 + B_2 Q_2)$; that is, by the vertical distance between points 5 and 11. We have, then, to plot this vertical distance radially all round a circle at points which represent the corresponding position of our crank pin of reference, in this case A, and afterwards determine and draw the corresponding scale. When the couple changes its direction from positive to negative, the distance must be plotted inwards towards the centre of the circle, the radius of the circle being chosen (at random) so that it is greater than the scale length of the greatest couple with which we are dealing, so that the curve never comes to the centre of the circle. Since we are now dealing solely with couples whose axes are horizontal, and from front to back of engine, or *vice versa*, it is clear that, the direction of the axis being known, we have only two variables to exhibit—*i.e.*, position of crank A, and magnitude of couple in plane 2, positive or negative. This produces curve A, in fig. 75. The scale is found as follows: If the force scale of the curve from which the measurements are taken is 1 in. = 8,000 lb., suppose, and the distance apart of the cylinder planes is 18 in., suppose, so that

$$\frac{d}{2} = 9 \text{ in.},$$

then 1 in. on the couple scale must represent $8,000 \times 9 = 72,000$ pound-inches, and the scale must be drawn accordingly

For the purpose of making the meaning of this curve absolutely clear, we shall take an illustration. When the crank A is in position 3, the couple acting on the engine tending to overturn it sideways is of magnitude $33A$, and is positive—*i.e.*, right-handed, as seen from the front, this

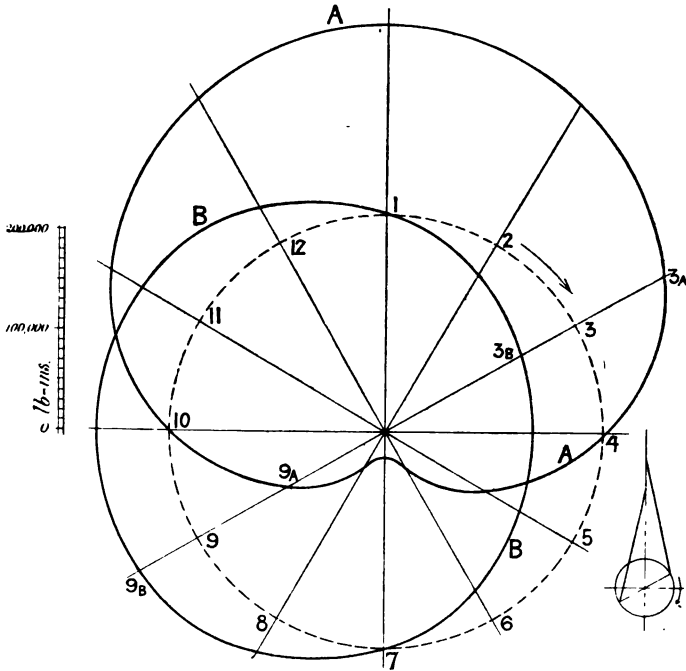

FIG. 75.—Curves showing couples acting on a two-cylinder engine with cranks opposite—A, plane 2; B, plane 3.

being indicated by the fact that $33A$ is plotted radially outwards. (In fig. 74, $A_2 B_2$ is a diagrammatic view of the crank shaft, as seen from the front. The couple $33A$ of fig. 75 is in the opposite direction to the couple $P_2 Q_2$,

shown in fig. 74). When pin A is at 9, there is a negative couple of magnitude 99A.

Plane 3.—Precisely the same principles are applied to the finding of couples in plane 3—the plan. Here, however, we have to take the *horizontal* distance between two opposite points of the force curve, for it is the horizontal components of the forces only which produce couples in the plan—that is, couples whose axes are vertical. These couples, represented precisely as before, are shown at curve B, fig. 75. They will be seen to be of much smaller magnitude than the couples represented in curve A. The curve, however, is of precisely similar character to curve A; that is, both are harmonic curves distorted by obliquity of the rod, the marked dent in curve A, which gives that curve a sort of heart shape, being merely due to the fact that the radius of the circle is nearly equal to the maximum A couple. If the curves had been plotted, as in Zeuner's valve diagrams, directly outwards from the centre of the circle, the two curves would nearly become two pairs of circles, such as are shown in fig. 72. This method, however, is not nearly so clear as the present one, because the essential difference between positive and negative is not so plain in the former.

Now, if this engine is to be balanced in respect of its couples, its force balance being already as nearly perfect as we can hope to get it without considerable complication of mechanism, we shall have, as before, to resort to weights on two flywheels. If we put one weight on one flywheel, the force balance will be destroyed, though the couple balance might be improved; but as no tests have ever been made as far as the author is aware to compare the relative disadvantage of want of force and couple balance, it is impossible to say definitely or generally what it is best to do in cases where only one flywheel is available. In the great majority of cases no balance weights are used at all, and this is probably best. The question only becomes of importance when the engine is supported on springs, or, being portable, has only light foundations. The couple balance can be much

improved without disturbing the force balance by means of two balance weights placed opposite to one another on two flywheels. To find the best value for these weights, we shall have to compound the two sets of couples already found. It has been proved that the couples in plane 1 are comparatively small, and may be neglected, or at anyrate it would be very difficult to diminish them ; so that we have

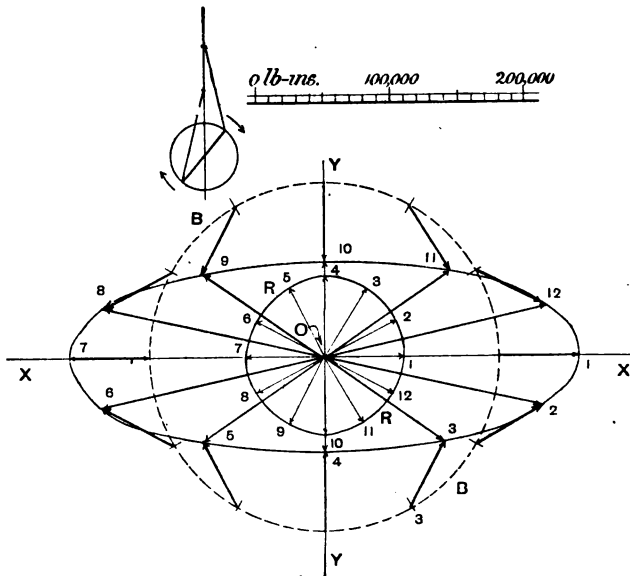

FIG. 76.--Curve showing resultant couple on a two-cylinder engine with cranks opposite.

to consider only couples in planes 2 and 3. The axes of both these sets of couples, and therefore those of the resultant couples, are always parallel to the central planes of the cylinders. If, then, a radial curve be drawn to represent the values of the resultant couple in magnitude and direction of axis, at all points of a revolution, this curve will lie in

plane 1. Now, as the axes of the couples due to two weights on opposite sides of two flywheels are also parallel to this plane, it behoves us to see how far the latter may be arranged to counteract the former. In order to do this the curve showing the couple to be balanced is obtained by compounding by the parallelogram law corresponding values of the two couples found from curves A and B in fig. 75, and plotting the resultants radially round the origin and numbering them, just as we treated the forces in fig. 57.

Take, then, two axes XX , YY , in a plane parallel to the central plane, intersecting at right angles in O , fig. 76. Directions measured along XX represent couples in plane 2, and those along YY represent couples in plane 3. To find the resultant corresponding to, say, position 3 of pin 1, set off a distance equal to $33A$ along OX in the positive direction, and $33B$ along OY in the negative direction—i.e., downwards (since $33B$ is plotted inwards). Complete the parallelogram. The distance $O3$, on fig. 76, then represents the magnitude of, and direction of the axis of, the resultant couple when the crank pin is at 3.* This process must be continued right round the circle, and we obtain, as before, an elliptic curve, which, in fact, is always the result of combining two harmonic motions of unequal amplitude, but equal period, at an angle (and in this case a right angle) to one another. This figure, though not exactly an ellipse, because its components are only approximately harmonic, is much nearer to it than the force curve on fig. 57, being quadrilaterally symmetrical. Consideration of the method of obtaining this curve will show that the magnitude of the resultant couple is given to some scale by the direct distance between the two points on the force curve. The axis is, of course, perpendicular to this line.

* The reference crank pin A is furthest away from us in the diagrammatic end view of the crank shaft, given at the top of fig. 76. The student must always keep clearly in his mind which is the reference crank pin, and from which side of the engine he is looking, otherwise he will infallibly get confused about the proper direction for his axis.

This curve then represents the couple to be balanced. Now, two rotating weights at opposite sides of two flywheels, revolving at constant speed, clearly produce a *constant* couple, whose axis revolves at 90 deg. behind the weights, and which, if each weight is put opposite the crank on its own side, is in general opposite in direction to the couple produced by the parts, and we are therefore here met by a difficulty precisely similar to the one which confronted us when dealing with force curves—that is to say, we have to balance a magnitude represented by the radii of an ellipse whose radii vectores are not angularly equidistant, by a magnitude represented by a circle whose radii vectores are equidistant. The result must evidently be only an approximation to perfect balance, and the amount of that approximation is determined precisely as before. By balancing various fractions of the maximum couple we should obtain curves which would be similar to the force curves given on fig. 59, but not so much distorted from the elliptic shape. In practice, for all-round balancing, we halve the sum of the maximum couple and the minimum, and strike the circle BB in fig. 76, and the equidistant radii of this circle are to represent successive values of the balancing couple, due to the rotation of the balance weights on the flywheels. But it must be noticed that any radius of this circle is at right angles to the plane containing the axis of the shaft and the centres of gravity of the balance weights in the corresponding position.

We have already proved the principle of the composition of couples, and it is therefore clear that the magnitude and direction of the axis of the resultant unbalanced couple will be found by joining the points on the circle with the corresponding points on the curve. Thus, 33, or O 3 on the central curve, represents the resultant couple when pin A is at 3. These resultants are, in fig. 76, plotted round the origin independently, producing curve RR, which it will be seen is very nearly a circle, whose radii are approximately equidistant, and which go the opposite way round to the

direction of rotation. Hence, as before, the couple balance may be made practically perfect by the same device as previously suggested—*i.e.*, arrange two auxiliary balance weights to rotate the opposite way round to the direction of rotation of the crank shaft with the same angular velocity, and to coincide with the primary weights at dead centres.

The balance circle BB having been determined on, it remains to deduce the magnitude of the balance weights. First, it must be noticed that, whether the flywheels are unequal or not, the balance weights must be such that their rotation produces equal centrifugal forces; that is to say,

$$W_1 R_1 = W_2 R_2,$$

otherwise the force balance will be disturbed. To determine the actual magnitude of the weights, find the couple represented by the chosen radius of the circle in fig. 76.

Suppose this represents 10,800 pounds-feet. This is the couple to be produced by the rotation of the weights.

Assume the distance apart of the centres of gravity to be 4 ft.

Then the force to be produced by *each* weight

$$= \frac{10800}{4} = 2700 \text{ lb.}$$

Suppose the radius of the centre of gravity of the balance weight to be

$$18 \text{ in.} = 1.5 \text{ ft.},$$

$$\text{then } \frac{M \times w^2 \times 1.5}{32.2} = 2700$$

$$M = \frac{2700 \times 32.2}{1.5 \times 2730} = 21.2 \text{ lb.}$$

where M is the magnitude of one weight.

The value of the unbalanced couple, as measured from the diagram, is about 4,850 pounds-feet, as against about 15,600 when no balancing is attempted.

Suppose the width of the bed plate is 4 ft. An unbalanced engine would be tilted off the ground on one side (unless held down) if its weight were less than

$$\frac{15600}{2} = 7800 \text{ lb.},$$

whereas the balanced engine would not be disturbed unless its weight were less than 2,425 lb.

CHAPTER XIV.

THE BALANCING OF TWO-CYLINDER ENGINES WITH CRANKS AT RIGHT ANGLES.

THE balancing of an ordinary locomotive is perhaps the most important of all problems of balancing, and we shall therefore take it as an example. But in order that the various curves may be comparable with those already obtained for other types of engines, it will be necessary to assume details and conditions differing considerably from those which are met with in actual practice. We shall, then, assume that the details of this imaginary engine are the same as we have considered throughout, the gauge being 4 ft., the distance apart of the cylinder centres 18 in., and the reference speed 500 revolutions per minute. We shall, as before, explain first a rough approximate method of obtaining the magnitudes of the weights—which method is commonly used in practice—and afterwards treat the question accurately.

I. Approximate method.

The usual method adopted in balancing locomotives is to consider each set of details separately, and to calculate the magnitudes of two weights, one on each driving wheel, which, placed opposite the crank, would balance a definite fraction of one set of the moving parts concentrated at the crank pin, and the resultant force due to which weights

acts in the central plane of the cylinder under consideration. This being done for each set of details, whether equal or not, results in two weights on each wheel. These are then combined into one on each wheel, as will be shortly explained. A better practice is that adopted in America, which is to divide each resultant balance weight so found into two or more parts, and to put one part on each of the coupled wheels. The effect of the weight so disposed on the engine as a whole is the same as regards couples in planes 2 and 3, but is different as regards couples in plane 1, which latter, as will be presently explained, are unimportant. The advantages obtained are that the vertical forces tending to lift the driving wheels off the rails independently of the rest of the engine (which forces will be presently discussed) are distributed among two or three wheels, and therefore the force tending to so lift any particular wheel is proportionally diminished. Also the vertical force due to the same reason which causes additional pressure between wheel and rail is diminished for one particular wheel, and the resulting wear of the tyres is most uniform.

There are various rules of thumb used by locomotive engineers to determine the fraction of the moving parts which is to be balanced. The difference between them is more or less unimportant. They all work out to about 80 per cent of the weight of moving parts, together with the whole revolving weight.

This method of calculating the weight required is as follows: Let W be (the calculated fraction of the one set of reciprocating parts + weight of pin + weight of cranks reduced to radius of pin) all supposed concentrated at the crank pin. Let r be the crank radius, and R the radius of the centre of gravity of the balance weight, which latter will be rather less than the half diameter of the driving wheel. The whole magnitude of the balance weight is then

$$W \times \frac{r}{R}.$$

Call this weight w .

Now, w must be divided between the two wheels, so that the resultant force due to the two parts lies in the central plane of the cylinder under consideration.

This may be done by the construction shown in fig. 60, or as follows :

Let $w_1 w_2$ be the two weights to be found, $d_1 d_2$ the known distances from the centre of gravity of the weights to the central plane under consideration.

Then we must have—

$$w_1 + w_2 = w,$$

and

$$w_1 d_1 = w_2 d_2.$$

From these simultaneous equations we deduce

$$w_1 = w \frac{d_2}{d_1 + d_2} \text{ and } w_2 = w \frac{d_1}{d_1 + d_2}.$$

This being done for each set of details results in two weights on each wheel, a large one and a smaller one, as shown in fig. 77. If, as usual, the details for both cylinders are equal, the ratio of these two weights will be $\frac{d_1}{d_2}$.

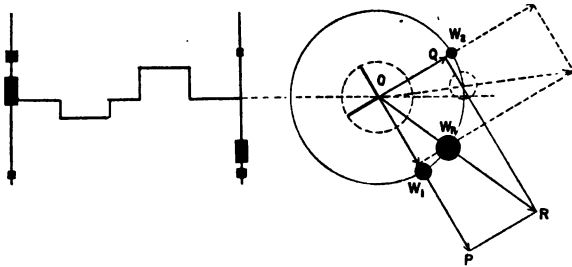

FIG. 77.—Approximate method of determining balance weights on a locomotive.

Now, when a wheel so loaded revolves, it is clear that each weight will produce its own centrifugal force. These forces are OP, OQ , acting radially outward.

The same effect will be produced on the engine as a whole by a single force O R, which may be produced by a single weight w_r , such that

$$\frac{w_r}{w_1} = \frac{O R}{O P'}$$

or, what comes to the same thing,

$$\frac{w_r}{w_2} = \frac{O R}{O Q'}$$

Hence, to find the actual magnitude of the weight, set out O P, O Q at right angles opposite the respective cranks and equal to $w_1 w_2$ respectively; complete the rectangle; then O R will represent one resultant weight. The other weight will be found by the construction shown dotted in fig. 77.

They may be calculated thus, without a diagram—

Magnitude of each resultant weight (if alike)

$$= \sqrt{w_1^2 + w_2^2};$$

Angle between them, seen in side elevation,

$$= 90 \text{ deg.} - 2 \tan^{-1} \frac{w_2}{w_1}.$$

Now, the effect of the two weights w_r on the engine, as a whole, is precisely identical with that of the four weights $w_1 w_2$, and that of these, again, is exactly the same as if the whole calculated weights w had been rotating in the central planes of the cylinders; and in future, therefore, we shall, for convenience, consider the effect of the weights w in the central planes opposite the respective cranks, instead of the weights w_r on the wheels. In fig. 78, the smaller of the two curves shows the result for one set of details of balancing 80 per cent of the moving parts, obtained as in fig. 57. By combining on this curve force 1 with force 10, 2 with 11, and so on, we obtain the larger curve, which is the resultant force curve, referred to the position of the leading crank pin.

Couples.—Fig. 79 shows in the same way as fig. 74 the way in which couples in planes 2 and 3 arise in a working

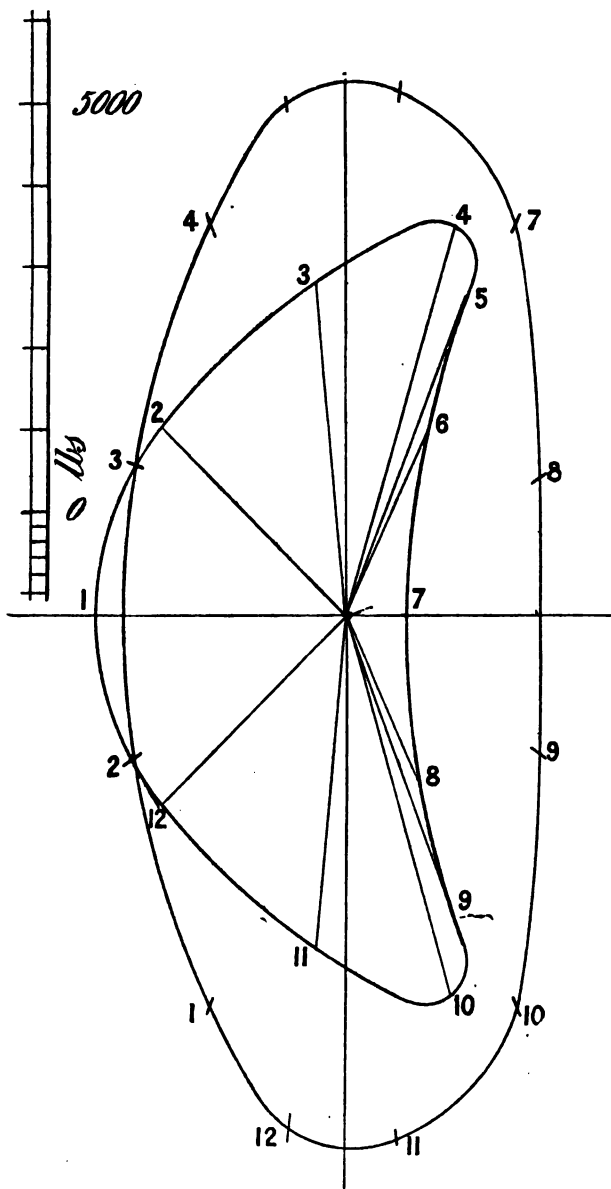

FIG. 78.—Curve showing resultant forces on a locomotive (engine travelling towards left).

locomotive or other engine with cranks at right angles. We have said enough in connection with fig. 74 to show how the magnitudes of the couples are to be obtained, and we shall, therefore, merely give the results of the process, fig. 80, from which an idea may be obtained of the way in which

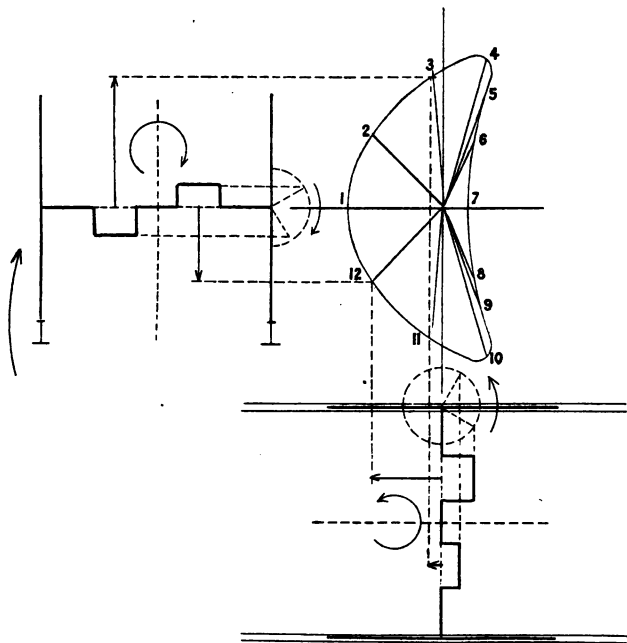

FIG. 79.—Figure showing the way in which couples arise in a working locomotive.

the couples vary both as regards magnitude and direction; as before, couples in plane 2 tend to overturn the engine sideways, and those in plane 3 tend to twist it off the rails about a vertical axis.

II. *Accurate method.*

According to this method the forces on the engine are treated separately from the couples, and it is shown how to adjust the weights so that any desired fraction of the total

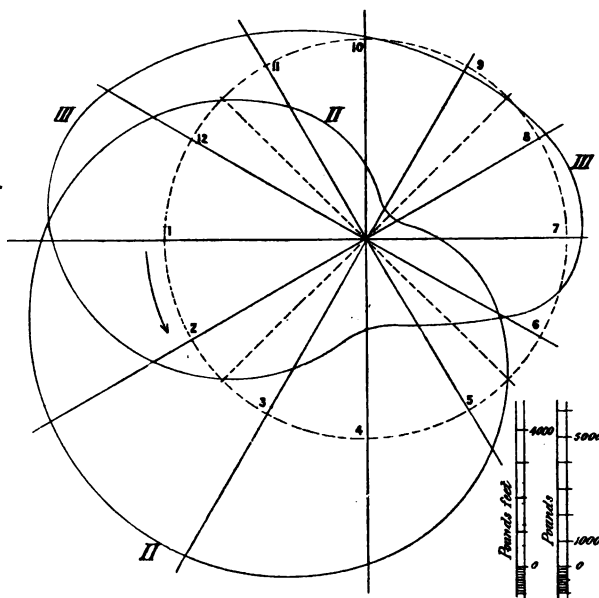

FIG. 80.—Curves showing the couples on a locomotive in planes II. and III., when 80 per cent of the parts are balanced.

force can be balanced as well as any independent fraction of the total couple.

The force curve of the unbalanced engine is shown in fig. 81. It is obtained from fig. 57, according to the principles explained in the last section—that is, by combining on fig. 57, which is the same curve as curve A A, fig. 81, force 1 with force 10 by the parallelogram law, and labelling the resultant 1; that is to say, for clearness

we are referring all the resultant forces to the position of the *leading* crank pin. But it must be noticed that, whereas fig. 57 is drawn for a vertical engine, a locomotive is a horizontal one, or nearly so. We have, for clearness sake, drawn the figure for an engine whose line of stroke is exactly horizontal. Therefore the curve given in fig. 57 must be turned through a right angle, with the longest radius vector pointing to the assumed position of the cylinders. Further, when a locomotive is travelling forwards the engine works the opposite way round to the direction we have throughout considered to be the positive one, because the cylinders are at the front. This will produce

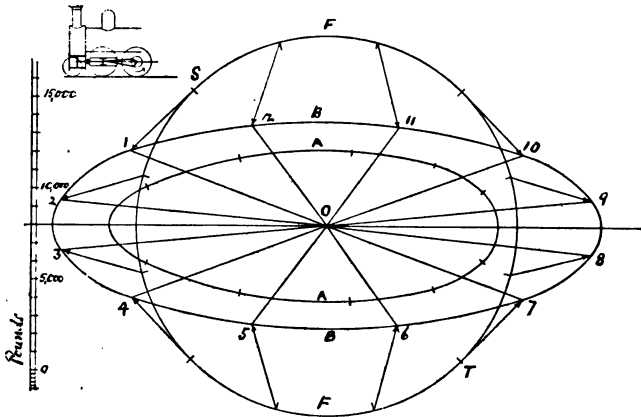

FIG. 81.—Inertia forces acting on a locomotive frame when unbalanced. A A, due to one set of details. B B, due to both sets.

a reversal of the direction in which the successive points 1, 2, 3, &c., move round the elliptic curve, fig. 57. The central curve A A, in fig. 81, shows the forces due to a single set of details working at 500 revolutions per minute. The larger curve B B shows the forces in play when both sets are acting simultaneously, the figures on it referring to the

position of leading crank. The student can only obtain an accurate general idea of the relative magnitudes of the forces in play in this and other types of engines by carefully comparing the different drawings.

Consideration of the various axes of symmetry of these curves is also a very instructive exercise.

The effect of these unbalanced *forces* on the engine considered as a whole is as follows: Consider, first, the horizontal components when the engine is travelling at a high constant speed. Suppose the speed to be that corresponding to 500 revolutions per minute. One might at first sight be tempted to think that the effect on the centre of gravity of the engine as a whole would be an alternate superposed acceleration and retardation, due to the alternate forward and backward force. This, however, is not strictly accurate, as the following considerations will show. It has been pointed out that velocity and acceleration are entirely independent of one another. In considering the acceleration, therefore, we do not need to confuse ourselves by considering what may be the velocity of the engine. The acceleration will be the same whatever the velocity, if the forces in play are the same. Hence we may consider the effect on the engine when it is suspended clear of the ground, with the wheels revolving at 500 revolutions per minute, in such a way that it cannot as a whole rotate about a vertical axis. Now consider the motion of a point on the *frame* of the engine. It will obviously be a small rapid forward and backward oscillation, due to the forces induced by the accelerations of the moving parts, for these are separate from the frame of the engine, and therefore produce forces which, as regards the frame and boiler, &c., must be considered as external forces. But no internal mutual force or stress in any body can generate motion of the centre of gravity of the body as a whole. When a gun goes off, the backward momentum of the gun the instant after firing is equal to the forward momentum of the shot. The centre of gravity of the shot and gun

taken together does not move a thousandth of an inch. There are forward forces subsequently applied to the gun to bring it to rest, which have the effect of causing this centre of gravity to move rapidly forward. But these are not internal or mutual forces between gun and shot. When a shell explodes, the centre of gravity of all the fragments follows precisely the same curve as the centre of gravity of the unburst shell, until the altered air resistance due to change of form takes effect. In the suspended working locomotive the centre of gravity of the whole remains absolutely at rest, though that of the moving parts moves backwards and forwards, and that of the frame, boiler, &c., forwards and backwards. So also when the locomotive is travelling the centre of gravity of the whole machine, including moving parts, moves slightly relatively to the boiler and frame, but its acceleration is absolutely unaffected by mutual forces. The centre of gravity of the boiler and frame, and the parts rigidly attached thereto, however does suffer alternate forward and backward disturbances.

Couples.—The couples in plane 1 do not practically vanish in engines of this type, as they did in the engine with cranks opposite. The effect of them is to produce variations in relative pressure between the front and back pairs of wheels and the rails, and they are quite unimportant, as they do not affect the stability of the engine, inasmuch as these pressures are directly upward and downward, having no lateral component; and also because the wheel base (which becomes the arm of the counteracting couple) is so long as to reduce the necessary forces to a very small quantity. As before, they are due to several causes.

(a) The irregularity of the tangential driving force causes slight variations in the angular velocities of the wheels when the engine is running at a constant mean speed. The reaction due to this produces a couple in plane 1.

(b) The actual driving force is the horizontal friction between the driving wheels and the rails acting at the level of the latter. This force does not pass through the centre

of gravity of the engine, which point is situated generally about 18 in. above the centres of the driving wheels. The resistance to motion or lag force, due to the inertia of the engine itself, acts through the centre of gravity, while that due to the train acts through the coupling or the buffers, according as the engine is pulling or stopping the train. Hence arises a couple which, when the engine is increasing in speed, tends to throw more weight on the hinder wheels, and when slowing down on the front ones.

(c) The angular acceleration of the connecting rods. Fig. 82, curve A A, shows the value of this angular acceleration of one rod. The values for its determination may be found as follows: Referring to fig. 56, and the explanation accompanying it,* we see that every point on the bed plate of the engine was supposed to be moving with a *constant linear velocity*, each along a different imaginary curve, each of which was a circular arc whose radius was equal and parallel to C Q. The result was that every point on the engine was moving with a constant angular velocity whose magnitude was $\frac{v}{r}$ radians per second, v being measured in feet per second, and r , the radius of the imaginary curve (which is, in fact, the crank radius), being measured in feet. The angular velocity of the engine as a whole is zero, since it always keeps parallel to itself. The acceleration of the truck in the direction in which it is moving is zero, its velocity being constant, and therefore its angular acceleration is also zero. The whole engine is, in fact, to be imagined moving just as the coupling rod of a locomotive moves relatively to the engine, every line in it keeping always parallel to itself, and therefore having as a whole no angular velocity, but every point describing its own circle. Now, since neither the angular velocity nor the angular acceleration of any extended part of the engine is affected by this assumed motion of the truck, it is clear that the connecting rod will have precisely the same angular acceleration when the engine is at rest as it

* See also the addendum to this explanation.

has when the engine is on the moving truck. Now, we know that in the latter case the point Q is at rest both in respect of its velocity and in respect of its acceleration.

Now, since the crosshead pin P has a linear acceleration on the moving truck of the value P M, it is obvious that the angular acceleration of the rod P Q must be the component of P M perpendicular to P Q in feet per second, divided by the length of the rod in feet. Now, P M = T Q, and the component perpendicular to P Q is given by the length of the perpendicular T S (see fig. 47) from T on to P Q. The point S is not lettered in fig. 56, to avoid confusion, but will be found in the corresponding position on fig. 47. Now, since the rod P Q is of constant length, it is obvious that the ratio $\frac{T S}{P Q}$ will be always represented on an appropriate scale by the length of T S, which scale must be afterwards determined as follows :—

Suppose linear accelerations are found in fig. 56 to a scale of

$$1 \text{ in.} = 1000 \frac{\text{ft.}}{\text{sec}^2},$$

the length of the rod, centre to centre, being 2 ft., the scale of angular accelerations will be

$$1 \text{ in.} = \frac{1000}{2} = 500$$

radians per second per second. This value of the angular acceleration is plotted radially round the crank-pin circle, as shown in fig. 82. The corresponding couple in pounds-feet, acting on the engine in plane 1, is found by multiplying this angular acceleration by $\frac{I}{g}$, where I = moment of inertia of rod about its centre of gravity = 59.2 pounds-feet², and g the acceleration due to gravity in $\frac{\text{ft.}}{\text{sec.}^2}$. I and g are both

constant; hence we have only to determine a scale of couples applicable to the rod, the scale being found as before, viz.,

$$1 \text{ in.} = 500 \times \frac{59.2}{32.2} = 920 \text{ pounds-feet.}$$

Now, in this case there are two rods which are being simultaneously accelerated or retarded angularly, simultaneous values being such as are shown on fig. 82, curve A, separated by a right angle. Now, the couples due to both rods are in parallel planes; hence the couple effect on the

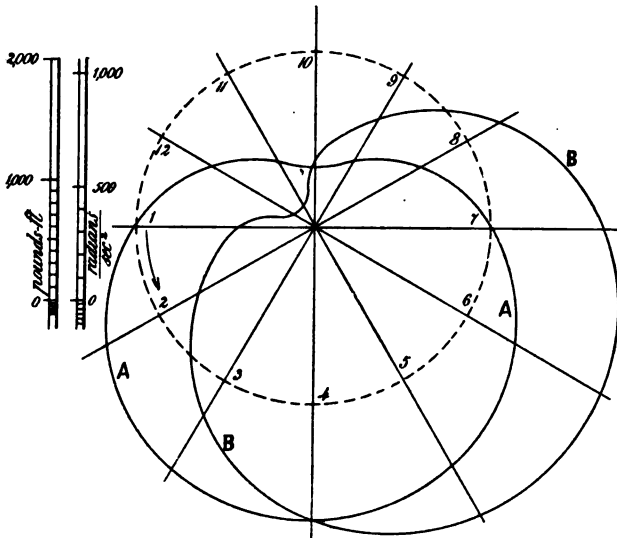

FIG. 82. —Angular accelerations and couples due to vibration of connecting rods.
A A, due to one rod, $I=59.2 \text{ lb.-ft.}^2$ B B, due to both together.

engine as a whole due to the angular acceleration of rod 1 in position 3, say, is precisely identical with that of rod 2 in the same position 3. It is thus obvious that to find the resultant effect of both rods, we have to add (in the algebraic sense) the corresponding values (those shown on curve A,

fig. 82, separated by a right angle), due regard being had to the positive or negative sign of the corresponding values.

This process produces curve B, in fig. 82, this curve showing, in the same measure as before, the resultant couple due to the simultaneous angular accelerations of both rods on the engine as a whole.

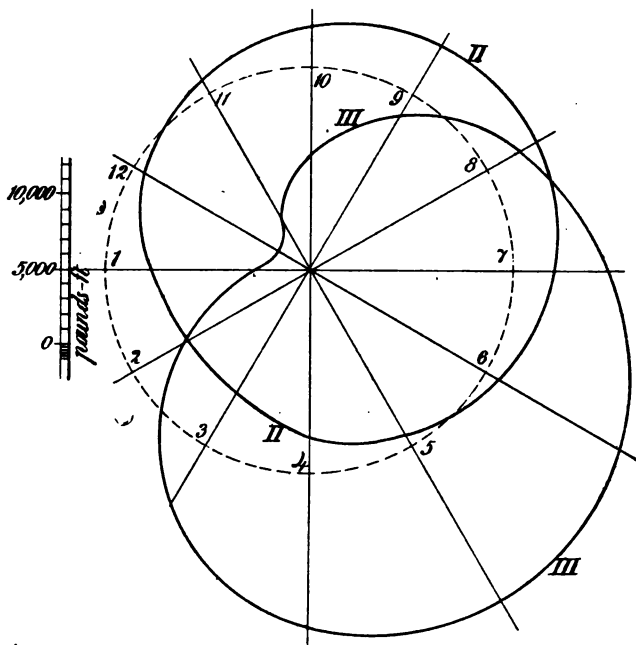

FIG. 83.—Couples in planes 2 and 3 acting on an unbalanced locomotive.

Planes 2 and 3.—Couples in these planes are obtained in a similar manner to those given in fig. 75—that is, by taking off from a force curve the vertical and horizontal distances respectively between the two points on the curve which correspond to any two simultaneous positions of the two cranks. This process produces the curves given in fig. 83,

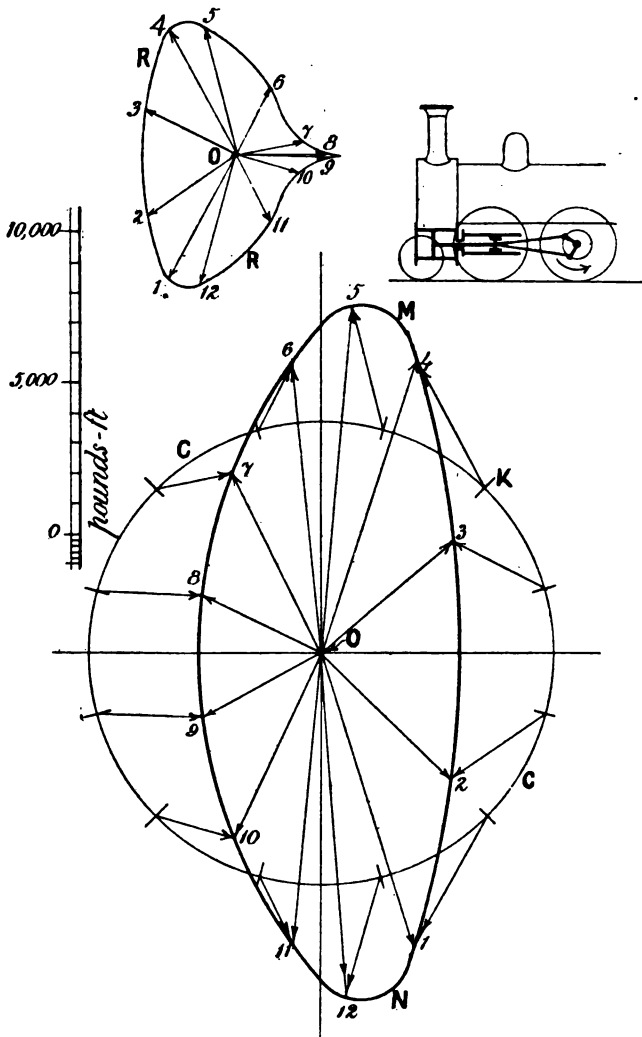

FIG. 84.—Curve M N. Resultants of the couples in planes 2 and 3 acting on an unbalanced locomotive Circle C C, balancing couple. Curve R R, resultants when balanced by a couple $OC = \frac{\max + \min}{2}$

curve II. being for plane 2, and curve III. for plane 3. They are combined into a resultant curve just as before, producing curve M N, fig. 84.

Consideration of the method of obtaining this latter curve and the corresponding one in fig. 76, obtained for cranks opposite, will show that the resultant couple is given by the actual length of the line joining two corresponding points on the force curve. The axis of the couple is, of course, at right angles to this line.

Now, great care and thought must be exercised in determining points on this curve, in order to obtain the proper direction for the axis. The engine has on these figures been imagined travelling towards the left, in order that the student may be able to exercise his mind on this subject. The couples in plane 2, tending to overturn the engine sideways, are shown positive on fig. 83 when the axis of the corresponding couple is pointing in the direction in which the engine is travelling.

The leading crank, to the position of which all numbers refer, is supposed to be the one nearest to us in all the figures given in this connection. Couples in plane 3, the plan, tending to twist the engine about a vertical axis, are shown positive when the direction of the axis is upwards.

It is thus clear that, in combining the couples, those which are shown positive in curve 2 must be plotted towards the left—*i.e.*, in the negative direction. The engineering student should always persistently exercise himself in thinking about things themselves, and not allow the symbol or lines which represent the things to distract his attention from what they represent. He should never, as it were, wrap up his ideas and thoughts in a parcel of symbols, and use rules of thumb about the symbols in order to save himself the mental trouble of untying the parcel. That is the mathematician's way of arriving at conclusions. It often serves the engineer's purpose very well as a much-needed check on his results, but is rarely to be relied on alone.

We have now arrived at the force and the couple which have

to be balanced. The ordinary method of determining the balance weights on a locomotive has been already discussed. That method, as we have seen, consists in taking an arbitrary fraction of the moving parts of each cylinder and balancing each separately by means of the principles already explained for a single engine. It is not possible by that method to deal separately with the force and couple, and the designer is left quite in the dark as to the results of what he is doing, trusting entirely to his rule of thumb to balance both the force and the couple. By the present method each is treated separately, and, though it involves a little more trouble, the designer at least knows what he is doing.

Strike circles FF and CC on each of the diagrams, fig. 81 and fig. 84, to represent the magnitudes of the desired balancing force and balancing couple. These must be determined with much care and foresight.

It is clear that from symmetry the direction of the counter-balancing force for position 1 will be opposite to the cranks and half way between them—that is, at 45 deg., as shown at OT, on fig. 81. Therefore, in accordance with the principles already explained in connection with fig. 57, &c., the resultant force is given in position 1 by S 1, and so on throughout. The circles shown on fig. 81 and fig. 84 are chosen as having radii representing a force and a couple respectively half way between the maximum and minimum values of the force or couple they have to balance. These would be used in a general case of an engine with cranks at right angles, but would probably be considerably increased in the case of a locomotive, and they are not put forward as being the most desirable magnitudes in such a case. The axis of the balancing couple, also from symmetry, would be parallel to the balancing force, but opposite in direction, and therefore the resultant couples are given, as already explained, by such lines as K 4. All such lines are plotted separately round the origin in fig. 84, producing curve RR, which therefore gives the resultant couples acting on the balanced engine.

This should be compared with the corresponding curve for cranks opposite (R R, fig. 76). Now, by inversion of the process of compounding which we have several times gone through, imagine the force OR , fig. 85, which is equal and parallel to OT of fig. 81, split up into two equal components OP , OQ , one acting on each wheel, acting at an angle POQ , as seen in side elevation. It is clear from what we have said that the force resultant of these will be OR acting on the engine as a whole, apart from the moving parts. It

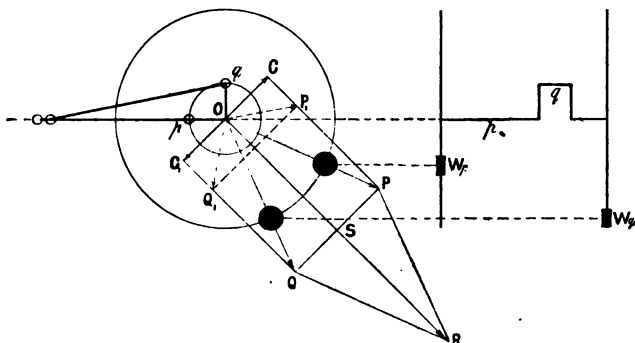

FIG. 85.—A method of determining the positions and magnitudes of balance weights in a locomotive.

is also clear that if the angle between OP and OQ be judiciously chosen, they may be made to exert a couple of any desired constant magnitude acting in the plane perpendicular to the paper whose trace is C_1, OC , and whose axis is therefore parallel to OR . For force OQ , for instance, acting on the further wheel, has precisely the same effect on the engine as a whole as two forces OC_1, OS , each acting through the centre of the further wheel. Similarly OP , acting on the nearer wheel, has the same effect as OC, OS acting through the centre of the near wheel. Now, OC and OC_1 form a couple in plane C_1, OC of the magnitude $OC \times 4$ ft. The other two forces, each equal to OS , being parallel, have a resultant OR acting through the centre of the engine. It

is thus clear that the two forces OP , OQ , acting as already explained, will produce on the engine a resultant balancing force of the desired magnitude OR , together with a balancing couple in the plane whose trace is $CO C_1$, and of magnitude $OC \times$ the gauge or distance apart of the centres of gravity of the balance weights; and if the force OP is made to act on the wheel on the same side as the crank p , to which OP is most nearly opposite (and similarly for force OQ), then this couple will in general act in such a way as to diminish the resultant couple on the engine. Now, since the couple which they will exert is $OC \times$ distance between the centres of gravity of the wheels, we have the following construction: Divide the desired balancing couple OC , fig. 84, by the gauge, and plot the force so found along OC and OC_1 , fig. 85. Bisect OR (equal to the radius OT of the balance circle on the force curve, fig. 81) in S , and draw QSP perpendicular; draw CP , C_1Q parallel to OR ; then OP , OQ will be the forces to be produced respectively by the rotation of the balance weights. Of these, OP will be on the nearer side, and OQ on the further one. The weights W_p , W_q can then be determined as before.

If the balance weight is required to be very light, the force balance OR might be very much reduced without a very evil effect. The couples are all-important in balancing a locomotive, and a balancing couple of the same magnitude as that produced by OP , OQ might be produced by any such forces as OP_1 , OQ_1 .

RELATIVE MOTION OF ENGINE AND CRANK SHAFT.

We now come to a question which did not occur in the stationary engines we have previously considered. In the latter the crank shaft was rigidly attached to the engine, except that it was allowed to rotate. It could have no motion of its own other than rotation, unless the engine had the same motion. In the case of a locomotive it is different. The axle boxes are not fixed in the frame, but are connected to it by means of springs—the frame of the engine being

either suspended from springs which are supported by struts pressing on the axle boxes, or being in some other way supported by springs pressing on the axle box.

The axle boxes slide vertically between the horn blocks, the latter being firmly bolted to the frame plates, and we have to consider what is the effect of this arrangement on the engine as a whole. It is clear that the alteration in effect is simply in respect of vertical forces and movements, for the crank shaft is virtually a part of the frame, except as regards its freedom in rotational and partial freedom in vertical movement, just as in the former case it was part of the bed plate in every respect except for its rotational freedom. Hence our previous investigation holds good for horizontal forces and couples in a horizontal plane, as we have treated it in respect of the engine as a whole considered as a rigid body. The crank shaft, however, cannot be considered as forming a rigid body with the engine in respect of vertical forces, so that we have now to consider the effect of mutual vertical forces between these two separate bodies. For instance, if the net upward force on the crank shaft due to centrifugal force, and the upward component of the thrust in the connecting rod and other forces, is at any time greater than that part of the weight of the engine transmitted through the struts, together with the weight of the shaft and wheels, then one or both driving wheels will be lifted off the rails independently of the rest of the engine; or if the resultant couple in plane 2 due to these forces is at any time greater than the passive couple due to the dead weight, which latter tends to keep the crank shaft and wheels in their normal position, then one or other wheel will be lifted off the rails independently of the rest of the engine, and produce a real "hammer blow" on the rails at that part of the revolution when this state of things ceases. In order to investigate these effects, we have to consider solely the vertical components of the forces on the crank shaft, entirely neglecting the horizontal ones. These are as follow:—

(1) Downward force due to thrust in the struts transmitted to the shaft through the axle boxes, together with the weight of shaft and wheels.

(2) Vertical components of centrifugal forces due to balance weights, the equivalent weights being, as before, considered as acting in the central planes of the cylinders.

(3) Vertical components of centrifugal force due to rotation of cranks and pins.

(4) Vertical components of total stress in connecting rod.

(5) Vertical components of those parts of the inertia forces due to the rods themselves which act at the respective crank pins, together with those of the component forces of the couples which produce angular acceleration of the rods.

The resultant of all these forces is opposed and balanced under normal conditions by

(6) Pressures between wheel and rails.

The method of obtaining curves (1)—(3) will be obvious from what has been already said. A separate curve is obtained for each cylinder. To obtain curve (4), a total force card is found from the given indicator card by subtracting the corresponding back pressure and multiplying by the area of piston. This card is then corrected for inertia of piston, rod, and crosshead [but not the connecting rod, as that is separately considered in curve (5)]. The resulting curve is given on the base of curve (4). From this curve the vertical component of connecting-rod stress is obtained and plotted, producing curves 1, 2, on base 4.

Curve (5) is obtained by finding the total inertia force due to the connecting rod by applying the principle of fig. 56. It will be found that the force component of the couple necessary to produce the angular acceleration of the rod is insignificant compared to the other forces in play.

It is clear that, since the rod is only connected to the rest of the engine by the crosshead pin and crank pin, this total inertia force must be counteracted by two forces acting through the centres of these pins. Now, since the centre of

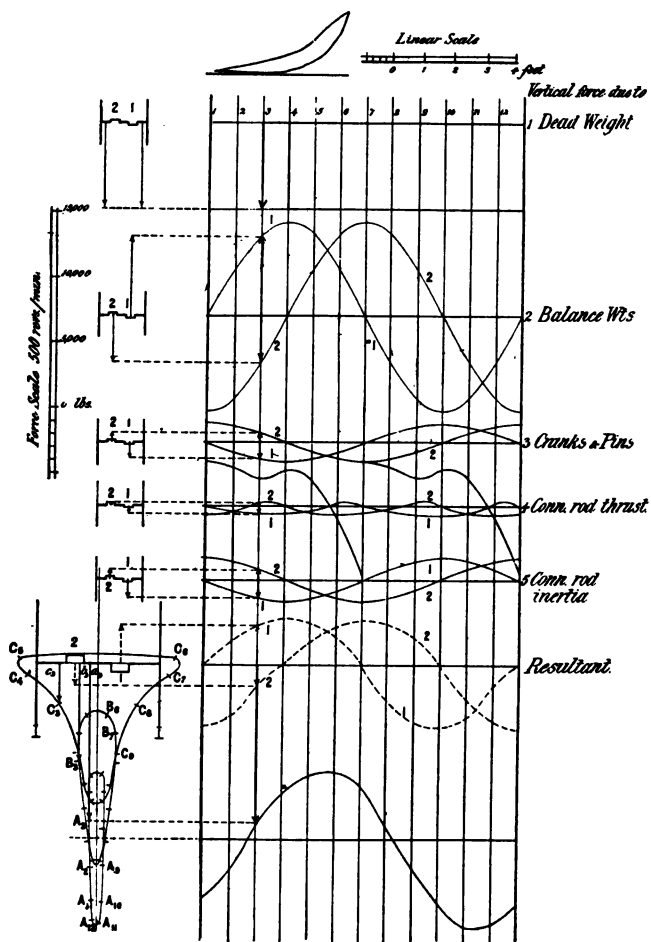

FIG. 86.—Curves showing the forces on the crank shaft of a locomotive.

gravity of the rod is a point fixed in the rod, the total force will be divided between the pins in a ratio inversely as the distances of the respective pins from the centre of gravity; therefore the force at the crank pin, due to the rod, is given by total inertia force due to connecting rod

$$\times \frac{\text{distance of centre of crosshead pin to centre of gravity}}{\text{length of rod centre to centre}}$$

The vertical component of this force is the value plotted in curve (5), each curve referring to one rod. In order to make the meaning of each of these curves clear, a small view of the crank shaft is given opposite each base, and position 3 being throughout taken as the example, each of the forces is shown in its proper position.

Curve A in the large front view of the crank shaft shows the magnitude and line of action of the vertical resultants of all the forces given in curves (1)—(5). Curves B, C will be shortly explained. They are obtained by finding twelve points on each of them, in the following manner: Again take position 3 as the example. It will be seen that each of the forces shown in curves (2) to (5) act in the central planes of the respective cylinders, and the dotted curve on base (6) shows the aggregate vertical forces on the respective crank pins. Now, in order to obtain point A_3 , for instance, the resultant of the two forces shown dotted, and a force equal to six tons acting at the centre of the shaft, is obtained by the link polygon method, and $a_3 A_3$ is the result, which therefore represents the resultant vertical force acting on the shaft in position 3. If this resultant at any time acts upwards, the consequence will be that both wheels will lift off the rails. If at any time it acts downwards, but outside either wheel, then the other wheel will lift off the rails.

It is obvious that each of the forces given in curves (2), (3), and (5) is proportional to the square of the speed, and they are therefore proportional to one another. Forces (4), which do not vary as the square of the speed, are small. Therefore it is clear that a good idea of the effect of increasing the speed will be obtained by finding the result of diminishing the

forces (1) inversely as the square of the speed, and altering the scale to suit. Thus, if we wish to know in a general way what will be the effect of doubling the speed, we can do so by dividing forces (1) by 4, and finding the result.

Curve A is drawn for a dead weight on each wheel of three tons, and for a speed of 500 revolutions per minute, not because that would be a likely speed for a locomotive to attain, but because it is the speed we have throughout considered, and it is therefore desirable, for uniformity and comparison, to keep to it. Now, if this speed were increased to $500 \times \sqrt{\frac{3}{2}} = 610$, curve B will give a fairly accurate idea* of the effect, if the force scale is altered in the ratio of $\frac{3}{2}$; that is, by making 1 in. on the new scale represent what 1.5 in. did on the original one.

In the same way curve C is the result of altering the speed in the ratio $1 : \sqrt{3}$; that is, of running at 860 revolutions per minute, corresponding to a speed of 124 miles per hour. It will be seen that at this speed one or both wheels would necessarily be off the rails for about one-third of a revolution, even if accidental oscillations did not occur of sufficient magnitude to bring about this result (which they certainly would do) long before such a speed was reached. It is instructive to notice the way in which the curves A B C open out as the speed is increased. In practice, of course, accidental oscillations due to such causes as slight irregularities in the laying of the rails would alter the forces (1) to such an extent as to throw the curve outside the wheel at a comparatively low speed, and every time they did so we should have a hammer blow on the rails.

From these curves of resultant forces on the crank shaft, it is easy to deduce the actual pressures between

* One of the negative components of curves 4 (viz., the force due to inertia of pistons and rods) does, however, vary as the square of the speed, and this produces a continually increasing error as the speed is increased.

either wheel and rail at any part of the stroke, either by the method of fig. 60, or by calculation. These are plotted radially *inside* the dotted circle given in fig. 87, in such a way as to show the simultaneous values of the pressures on either wheel, corresponding to curve B in fig.

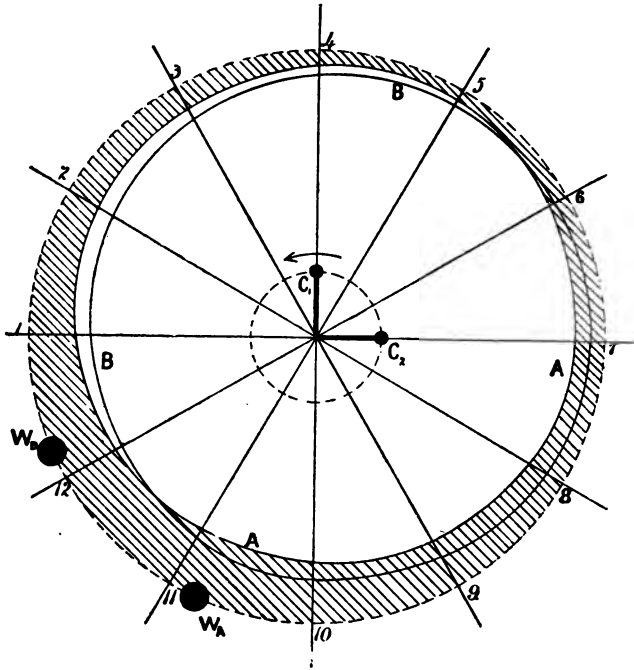

FIG. 87.—Curves showing variations of pressures between driving wheels and rails.

86 ; curve A referring to the wheel nearest to the crank pin of reference.

If the greater part of the engine's life were spent in running at the standard speed, and if the wear of the tyres at any point be proportional to the pressures between wheel

and rails at that point, these curves will give in an exaggerated form the profile of a pair of much-worn wheel tyres. The hatched area then shows the amount of wear of the original tyre of one wheel. But it is probable that even in this case the wear, as shown by this profile, will differ considerably from that of an actual wheel, because a great amount of wear will take place at those parts of the wheel on which in general the wheel skids most—that is, the part of the wheel which is on the rail at the time when a large twisting moment on the shaft is combined with a small pressure by the wheels on the rails. One such part will clearly be that which is shown in fig. 87 to be least worn (viz., positions 4—6), so that the tendency to skid to some extent equalises the wear of the wheels. The figures on the outer circle show the points of the tyres of the wheel which are on the rails at the corresponding point of the revolution of the crank pin. The order of these points, of course, is in the opposite direction to that in which the wheel revolves.

EQUILIBRIUM OF INTERNAL FORCES AND STRESSES IN A LOCOMOTIVE—"D'ALEMBERT'S PRINCIPLE."

In discussing the forces acting on a crank shaft of a locomotive, we took the pressure on the struts as constant. It is, however, clear that if the body of the engine is by any means lifted or depressed during working, this pressure will not be constant, on account of the elasticity of the springs. Or, if the engine rocks laterally, though the total pressure on the two struts may remain the same, the distribution of it on the two sides will be altered in such a way as to vitiate the results shown in fig. 86 by altering the downward pressures given on curve 1. We shall, therefore, briefly consider the lateral rocking of locomotives, due to couples arising from the varying stresses in and inclinations of the connecting rods.

Now, there may be accidental disturbances of this nature of which we cannot possibly take count, such as, for

instance, those due to irregularities in the laying of the rails, or to accidental synchronisation at a particular speed of disturbing and periodically recurring couples or forces with the corresponding natural period of oscillation of the engine, such as would produce by their cumulative effect oscillations of dangerous amplitude. But there are also regular periodic disturbances, due to the action of the mechanism, which, as they form a valuable illustration of the meaning of the term "rigid body," and as a knowledge of them is necessary to the exact comprehension of the working of a locomotive, we shall now discuss.

Imagine, first, that the axle boxes are fixed relatively to the horn blocks by fastening the struts in their guides, and that the crank shaft is blocked so that it cannot rotate. Consider what will be the static effect of admitting steam to the front of the cylinder, the "front" referring to the forward part of the engine. It will obviously be to produce a forward force on the cylinder—that is, a force in the direction in which the engine travels—and a backward one on the piston.

The forward force on the cylinders is at once transmitted to the frame plates through the cylinder bolts. The backward force on the pistons is transmitted through the connecting rods to the crank shaft, and thence to the frame plates. The two equal and opposite forces in the frame plates neutralise one another, producing in so doing a tensile stress in those plates.

Now, it is obvious that precisely the same state of stress would have been induced in the engine if we had assumed that the stress had originated in a tendency to expand the connecting rod itself, instead, as is actually the case, of the steam in the cylinder. In the former case the steam in the cylinder would merely act as a strut in transmitting the stress in the rod to the back of the cylinder.

Now consider the connecting rods. They are in a state of

compressive stress, the force in each of them being greater than the force in the corresponding piston rod in a ratio

$$= \frac{1}{\text{cosine of angle of inclination}}$$

Suppose one rod is inclined upwards, fig. 88. The cross-head end of this rod tends to force the crosshead downwards with a force P as well as horizontally forwards with force R , this latter being in reality the reaction due to pressure on the piston, while the crank-pin end of the rod forces the crank pin upwards with a force equal to the downward force at the crosshead end P , and also horizontally backwards with a force S equal to the backward force on the piston - R . Now, it might be thought at

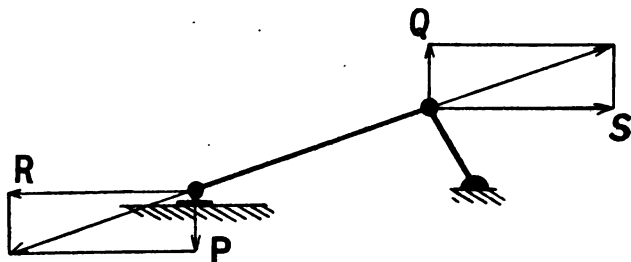

FIG. 88.

first sight that the two equal and opposite vertical components P , Q , acting on the frame plates at the two ends of the rod, would produce a couple PQ , tending to tilt the engine forwards. But it must not be forgotten that the two equal and opposite horizontal components acting on the frame are not in the same straight line, and therefore produce a contrary couple RS , and it will be found on examination that these two couples exactly balance one another—that is, one is right-handed and the other left-handed, and their moments are equal, and that, therefore, any stress in the connecting rod produces no couple on the engine as a whole. Similarly, equilibrium of forces and couples will be found to subsist whatever complicated state

of stress is assumed in the locomotive. For instance, suppose that certain simultaneous stresses in the connecting rods produce a couple on the crank shaft in a transverse vertical plane, which, if the latter were independent of the rest of the engine, would tend to tilt one of the wheels off the rails. The crank shaft not being free to move, this couple is *immediately* transmitted to the engine itself through the struts which are rigidly fixed to the frame, existing in those struts as an increased vertical stress in one and a diminished one in the other. Now, the principle under discussion is this : The connecting-rod stresses, in addition to producing a couple on the crank shaft, also produce an opposite and precisely equal couple on the engine itself, originating in the first place in the transverse vertical plane through the crossheads. If the engine is perfectly rigid, these two equal and opposite couples will *instantaneously* neutralise one another in the engine itself, producing, in so doing, a twisting stress in the engine between the vertical transverse planes passing through the crank shaft and the crossheads respectively. It is the assumed rigidity of the body which causes the transmission of stress to be instantaneous. In fact, a rigid body might almost be defined as one which transmits stress instantaneously. Hence we see that if the crank shaft were rigid with the engine no stresses in the connecting rods could alter the pressures between driving wheels and rails, because any such action that might be produced on the crank shaft would be instantaneously neutralised by a readjustment of pressures in the struts, such a readjustment being the effect of the opposing couple transmitted through the engine from the crossheads.

Now consider the forces and afterwards the couples due to stresses in the rods when the rigid connection between the axle boxes and horn blocks is done away with, the engine being, as usual, supported on springs, but the wheels being still prevented from rotating. When steam is admitted to the cylinders, the tendency of the resulting compression in the rods is, as before, to force the crossheads forward and

the crank shaft backwards, these tendencies being, after transmission through the steam in the cylinder, as before, exactly neutralised by the horizontal stress in the frame plates, that stress being precisely equal to that subsisting in the first case. With the vertical forces, however, it is different. The crosshead is, as before, forced downwards and the crank pin upwards, this latter force, however, not being sufficient to lift the driving wheels off the rails. The result will therefore be that the engine frame is forced downwards relatively to the crank shaft. Now, the engine frame, being free to move vertically, will respond to this downward force, and will in so doing further compress the springs on which it rests until all the *springs* together are bearing not only the weight of the frame, &c., but also this additional downward force. This net addition to the weight on the springs does not affect the total pressure on the rails. It is caused, of course, by the vertical component of the connecting-rod stress. This component presses the engine down exactly as hard as it presses the crank shaft up, and so on the whole is without effect on the total pressure on the rails. If all the pairs of wheels were on separate weighing machines, the result would be found to be that, while weight was taken off the driving wheels, the load on the other pairs of wheels was increased in such a way that the total weight on all the rails is constant, and has a constant moment about any point. At the same time there is additional stress in the struts which press on the driving-axle boxes. This equilibrium cannot be established, nor can additional stresses come on the struts until the springs are sufficiently compressed by a downward displacement of the frame relatively to the crank shaft. When this displacement has taken place and equilibrium under the new conditions has been established, the whole engine again becomes a virtually rigid body, and subject to all the laws of rigid bodies, until that system of forces is again altered, when it again assumes a new position of equilibrium. Now, it is obvious that since the mass of the frame, boiler, &c., is very large, this displacement

requires time to develop itself. The relative vertical force produces an immediate acceleration of the frame, which, since the force is comparatively small and the mass large, will be a small one, and as the displacement increases the continually-increasing force in the springs will make the acceleration smaller and smaller until it vanishes, when equilibrium has been established. However, equilibrium will ultimately be established *if time enough is allowed*. But if the force on the piston be released or reversed before the displacement has had time to develop, it is clear that no additional force will come on the driving-axle struts due to the stress in the rod, and it is precisely this which we have assumed in taking the load on the struts as constant. The assumption is that the speed is so high that before a displacement can take place the force producing the acceleration is reversed.

We have considered the vertical forces only, as being easier to understand, but the explanation is exactly similar in relation to the couples. Suppose that, owing to stresses in the two connecting rods, there is produced a couple on the frame in plane 2—that is, tending to overturn the engine sideways about a horizontal fore-and-aft axis, which, if the engine were a rigid body, would by transmission immediately counteract the couple produced on the crank shaft as far as the effect on the engine as a whole is concerned. The couple produces an angular acceleration of the frame relative to the crank shaft, which, if allowed time to develop, would produce an angular displacement of sufficient magnitude to affect our results by altering the relative pressures on the two struts; but, owing to the great moment of inertia of the engine about a horizontal fore-and-aft axis, the time required is so long that no appreciable displacement does take place in the short time during which the angular acceleration is allowed to act. When the speed is low this is not the case—that is, an appreciable angular displacement does take place, as will be apparent to anyone watching a slowly approaching locomotive from the front, when the oscillation due to this cause is plainly apparent.

CHAPTER XV.

GENERAL REMARKS ON BALANCING.

The student will now be in a position to understand the following remarks, which sum up the whole problem of balancing.

If in any system composed of two or more bodies at rest, whether connected together in any way or not, the system as a whole being perfectly free to move in any direction, there is introduced a relative motion between any or all such parts by means of a mutual force acting between them, but without any force of whatever kind acting from outside on any part of the system, then the centre of gravity of the whole system will remain at rest ; that is to say, the momentum of any part of the system will at any instant be precisely equal and opposite to that of the whole of the rest of the system.

If one of the parts of the system be constrained by any kind of fastenings, by gravity, or by means of any passive forces such as friction, or by any other constraints whatever, then those constraints will experience a stress equivalent numerically to the rate in pounds-feet per second every second at which they destroy the momentum which would be generated in that part of the system by the mutual force if the constraints did not exist. In other words, the stress experienced by the constraint at any instant is a reactionary force of such magnitude as is required to communicate to the centre of gravity of the system as a whole the actual acceleration which that point has at the given instant, due to the absolute motion of the various parts of the system, and their geometrical connection with the centre of gravity.

Such a force as this is what is known as the unbalanced force in a working engine. For instance, if, acting on an engine fixed on foundations, running at 500 revolutions, and

weighing altogether 3 tons, suppose, there is at any instant an unbalanced force of 10,000 lb. in any direction, which, to fix our ideas, we shall imagine acting vertically upwards; this is a sign that at that instant the centre of gravity of the engine as a whole is moving with an acceleration whose direction is vertically downwards and of magnitude

$$\frac{10000 g}{3 \times 2240} \text{ ft. per second per second,}$$

this acceleration being due to the relative motion of the parts of the engine. Observe that this statement does not imply anything about the *velocity* of the centre of gravity, but only its acceleration. In thinking of this action the student must keep clearly in his mind the distinction between the forces acting *from outside* on the engine, and the equal and opposite forces exerted by the engine on the fastenings; that is to say, the engine must be mentally isolated from the foundations, and the weight of the engine (that is, the force on it due to the pull of gravity) be pictured as a separate force acting on it from outside. Likewise the passive upward supporting pressure of the foundations on it, which when the engine is at rest, exactly balances this downward gravity force, must also be mentally pictured as a perfectly distinct and separate force of definite, though variable, magnitude. Now, in the example just quoted, what we have is this—the resultant of the *whole* of the forces acting *on* the engine *from outside* acts vertically *downwards*, and is of magnitude 10,000 lb. weight. The components of this 10,000 lb. are—

- (1) Weight of engine and all its parts (downwards).
- (2) Upward supporting pressure of the foundations.
- (3) Tension in the foundation bolts.

These are absolutely the only forces acting from outside on the engine. The inertia forces do not act from outside in this sense. These are separately taken account of by substituting for them a motion of the centre of gravity of the engine as a whole. This motion generates the “action,” while the outside acting forces are the “reaction.”

In order to make this point quite clear, we shall briefly consider a simple illustration. Suppose an engine whose weight is M lb. has its connecting rod taken off, and its crank shaft set rotating at a high rate of speed w . Let the weight of the crank shaft be m lb. Let G_B , fig. 89, be the centre of gravity of the bed plate, and the circle $G_c G_c$ be the path of the centre of gravity of the crank shaft. Let the force due to rotation of the cranks be f lb.; f is therefore the magnitude of the resultant force of constraint on the engine as a whole. Our principle is that

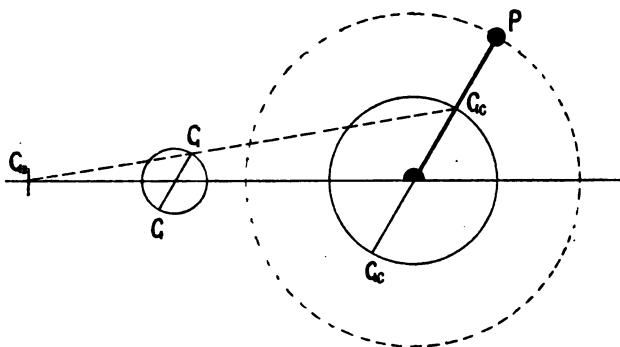

FIG. 89.

because this force of constraint is f lb., the acceleration of the centre of gravity G of the whole engine with crank shaft must be $\frac{f \times g}{(M + m)} \frac{\text{ft.}}{\text{sec.}^2}$ in direction $G G_c$, parallel to $G_c G_c$. As this acceleration is of constant magnitude, and its direction rotates uniformly, it is clear that, if the theory is correct, the centre of gravity of the whole engine must describe a circle with the same angular velocity as the point P does. From the geometry of the figure it is obvious that the point G does so, the ratio of the two radii being $\frac{m}{m + M}$. If this engine, so working,

were floating in mid-space, so as to be perfectly free to move, the point G would remain at rest, the engine itself moving in such a way as to allow of this.

These considerations show that it is possible to deduce the force curve as given in fig. 56 from a curve showing the path of the centre of gravity of the whole engine, or *vice versa*. The processes are complicated and difficult to understand, involving several operations of graphical differentiation and integration. They are not so accurate as those previously given.

Thus far we have been considering the equilibrium of the centre of gravity of the engine as a whole, and have shown that it is the outside acting forces which produce acceleration of that point, and that the lag force of that point forms a complete balance to all external forces. We might, if we had wished, have taken (instead of the separate engine) the engine and foundations together, when the results would have been similar; or, for the matter of that, we might have considered the engine and the whole earth. In this latter case it is the centre of gravity of the engine + whole earth that remains at rest. All these different ways of regarding the problem are entirely consistent with one another, and with the general theory laid down above. Again, we might have taken the bed plate of the engine apart from the moving parts. In this case any action, of whatever kind, due to the presence of the moving parts, must be considered an outside force with respect to the bed plate. The bed plate is at rest; therefore all the outside forces on it exactly balance one another, there being no lag force such as we had to consider in the case of the whole engine.

The general theory of unbalanced couples is very similar.

In every solid body there are three lines, mutually perpendicular, and all passing through the centre of gravity, which are such that the body will spin round on any one of them as axis, without producing either a force or a couple. There may be more than three such lines if the shape of the body observes certain rules as to symmetry, but there are

always at least three. If the body is spun round any line passing through the centre of gravity, there will be no resultant centrifugal force produced on it, but in general there will be a couple acting on the axis.

Thus, if a straight rod AB , fig. 90, is spun round the axis yy , it is obvious that there will be a couple PQ tending to set the rod in the line xx . There will be no such couple

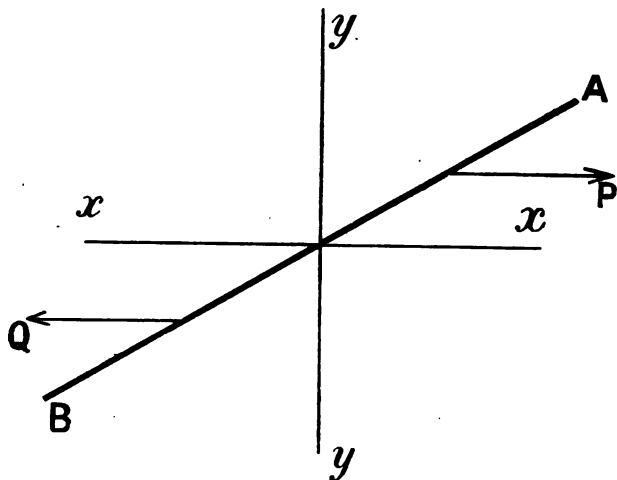

FIG. 90.

if the line yy is perpendicular to the rod. These three lines are called *principal axes* of the body.

When a double engine is working it is clear that the direction of these principal axes will alter for each position of the moving parts.

If such a working engine were floating in mid-space, the result would be that the engine itself would move in such a way that the principal axes would remain at rest, wherever they might happen to lie in relation to the engine itself.

These lines cannot be angularly displaced without some outside couple acting on the engine.

If one part of the engine—the bed plate—be either fastened down by bolts, or in some other way constrained to remain at rest, then the resultant couple which must act on the engine due to the fastenings—or, in other words, the resultant couple which the engine will exert on the constraints in any principal plane—is numerically equal to the product of the angular acceleration of the two axes in that plane with the moment of inertia of the engine at that instant about the other axis. This theorem cannot be fully worked out here, but it brings out very clearly a further analogy between linear and angular motions.

INDEX.

Acceleration of Piston, Method I.	108
Acceleration of Piston, Method II.	111
Acceleration of Piston, General Method	120
Acceleration of Connecting Rod	123
Acceleration, Angular, of Connecting Rod	126, 180
Alteration of Power and Work Ratio in Compound Engines	72
Area of Crank-pin Bearings	29
Area of Connecting Pipe in Compound Engine	69
Area and Stroke of Piston	6
Area of Ports	7
Balanced Cranks, Design of	141
Balance Weights, Single	132, 158
Balancing Couples	155, 166, 189
Balancing Forces	127, 132, 177
Balancing, Two-cylinder Engine, Cranks Opposite	159
Balancing Two-cylinder Engine, Cranks at Right Angles	170
Balancing, General Theory of	201
Bearings, Area of Crank-pin	29
Bending Moments on Crank Shaft	30
Bending and Twisting Moments Combined	32
Bolts, Size of	40
Bolts, Turned Down on Shank	41
Caps, Bearing, Depth of	41
Centrifugal Force, Theory of	98
Centrifugal Force Due to Crank Shaft	102
Clearance, Intermediate Effect of	60, 78
Combination of Bending and Twisting Moments	32
Combination of Couples	149
Compound Engines	47
Compound Diagrams	67, 75, 84
Connecting Pipe in Compound Engine	69
Connecting Rod, Motion of	121
Connecting Rod, Acceleration of	123
Connecting Rod, Angular Acceleration of	126, 180
Constriction of Exhaust	67
Correction of Indicator Card for Inertia	113
Couples, Theory of	145
Couples, Composition of	149
Couples, Curves of, on Engines	155, 164, 166, 176, 184
Crank Shaft, Diameter of	30, 38
Crank Shaft, Twisting Moment on	92
Crank Shaft, Forces on	191
Cranks Balanced, Design of	141
Crosshead Pin, Size of	43
Curves of Accelerating Forces on Piston	112
Curves of Angular Acceleration of Connecting Rod	182

	PAGE
Curves of Bending and Twisting Moments on Crank Shaft	36
Curves of Couples on Engine	164, 166, 176, 183, 184
Curves of Cut-off, &c., in Link Motion	26
Curves of Forces on Crank Shaft	191
Curves of Inertia Forces Due to Moving Parts only	131, 133
Curves of Pressures in Cylinders	2, 52, 62, 75, 84
Curves of Pressures on Wheel Tyres	194
Curves of Twisting Moments on Shaft	92
Curves of Valve Position	9, 14, 20
Curves of Resultant Unbalanced Forces	135, 160, 177
Cut-off, Lap Required for Given	11
Cut-off, Variable	14, 26
Cut-off in Low-pressure Cylinder	64, 78
Cylinder, Size of Single	2
Cylinder, Size of Compound	57
Cylinder Ratios	37
Cylinder Face, Design of	8
D'Alembert's Principle	195
Details, Dimensions of	27
Diagrams, Indicator	3, 52, 62, 75, 84
Diagrams, Inertia	106
Diagrams, Valve	9, 14, 20
Diagrammatic Compound Engine	50, 60
Die, Slip of, in Link	22
Double Crank Shafts, B. and T.M.	34
Drop of Pressure in Compound Engines	54, 63
Early Cut-off in Low-pressure Cylinder	64, 78
Eccentrics, Size of	44
Elliptic Valve Diagrams, Single Valve	9
Elliptic Valve Diagrams, Meyer's Gear	13
Elliptic Valve Diagrams, Stevenson's Link	20
Energy in Flywheel	87
Equivalent Twisting Moment	31
Exhaust, Constriction of	67
Exhaust Port, Volume of	71
Expansion Valves	13
Flywheels, Energy Stored in	87
Flywheels, Function of	86
Flywheels, Weight of	87, 89
Force, Centrifugal	98
Force Curves Due to Inertia	127, 130, 133
Force on Locomotive Engine	177
Force on Locomotive Crank Shaft	191
Hyperbola, Construction of	4
Hyperbola, Area of	5
Indicator Diagrams	3, 52, 75, 84
Inertia, Correction of Card for	112
Inertia Diagrams	106
Inertia, Moment of	97
Inertia of Moving Parts, Theory of	97
Intermediate Clearance, Effect of	60, 78
Internal Forces and stresses in Locomotive	195

	PAGE
Joy's Valve Gear	26
Lap Required for Given Cut-off	11
Lap, Variable, of Expansion Valve	14
Lead, Variation of, in Link Motion	26
Link Motion, Stevenson's	18
Link Motion, Curves of Valve Position	20
Locomotive, Balancing of	171, 176
Locomotive, Couples on	184
Locomotive, Crank Shaft Diameter	88
Locomotive, Effect of Inertia Forces on	178
Locomotive, Forces on Crank Shaft	191
Locomotive, Effect of Increase of Speed in	193
Locomotive, Internal Forces and Stresses	195
Locomotive, Pressure on Tyres	195
Locomotive, Relative Motion of Engine and Crank Shaft	188
Maximum and Minimum Speeds due to Variable T.M.	96
Meyer's Gear, Valve Diagram	13
Moments, Bending and Twisting, on Crank Shaft	35
Moments, Variation of Twisting	90
Moments of Inertia	97
Motion of Connecting Rod	121
Motion, Relative, of Engine and Crank Shaft	188
Moving Parts, Inertia of	97
Pin, Crosshead, Size of	43
Pin, Valve Rod	45
Piston, Acceleration of	108
Piston Area and Stroke	6
Piston Rod, Size of	29
Pipe, Connecting Area of	69
Point of Suspension of Link	23
Position of Expansion Eccentric	13
Port, Area of	7
Port, Volume of Exhaust	71
Power of Engine	3, 48
Pressures Between Wheels and Rails	194
Pressure, Drop of	54, 63
Range of Temperature in Cylinders	58
Rat'io of Cylinders	59, 72
Re-admission by Expansion Valve	17
Reasons for Compounding	47
Receiver, Intermediate, Effect of	62, 78
Receiver, Volume of	80
Rectangular Hyperbola	8
Relative Motion of Engine and Crank Shaft	188
Remarks on Balancing	201
Representation of Couples	148
Resultant Couples on Engine	186, 184
Shaft, Crank, Size of	80
Shaft, Locomotive	38
shaft, Forces on	191
Single-acting Engine	114
Single Balance Weight, Effect of	182, 158
Stevenson's Link Motion	18
Stevenson's Diagrams of Lead, Slip, Travel, and Cut-off	26

	PAGE
Temperature Range in Cylinders	58
Theory of Couples	145
Theory of Inertia of Moving Parts	97
Travel of Valve in Link Motion	26
Twisting Moments on Crank Shaft.....	90
Two-cylinder Engine, Balancing	159, 170
Tyres, Wear of, in Locomotives	195
Valve Diagrams, Elliptic.....	9, 13, 20
Valve Gear, Joy's	26
Valve, Lap of	11, 16
Valve Rod Pin	45
Volumes of Cylinders	2, 48
Volume of Ports	71
Volume of Receiver	80
Weight of Flywheel	87, 89
Weight, Determination of Balance	139, 170, 176
Willans Engine	118

THE Practical Engineer.

Published simultaneously in London and Manchester.

EVERY FRIDAY, PRICE TWOPENCE.

THE BEST WEEKLY JOURNAL
OF
MECHANICAL AND MOTIVE POWER ENGINEERING

WRITTEN BY PRACTICAL ENGINEERS FOR PRACTICAL ENGINEERS.

The Journal has a large staff of Contributors, of special experience in every branch of Engineering to which it is devoted, so that its readers are kept fully informed with respect to the latest improvements and most modern practice in Steam and Gas Engines, Hydraulic Engineering, Electrical Engineering, Boiler Making, Machine Tools, &c.

SUBSCRIPTION 10s. PER ANNUM

(Including Free Copy of Pocket-book).

POST FREE TO ALL PARTS OF THE WORLD.

Foreign Remittances by International Money Order.

**If you are not already a reader, permit us to solicit the
favour of a year's trial.**

THE TECHNICAL PUBLISHING CO. LIMITED,
31, WHITWORTH STREET, MANCHESTER,
ENGLAND.

SEND POST CARD FOR SAMPLE COPY.

PUBLISHED ANNUALLY.

THE "PRACTICAL ENGINEER" POCKET-BOOK.

REVISED AND GREATLY ENLARGED.

LIST OF CONTENTS.

STEAM BOILERS.—Types, Power, Heating Surface, Strength of Riveted Joints, Furnace Tubes, Flat Surfaces, Dish Ends, Proportions, Chimneys, Flues, Safety Valves, &c.; Hydraulic Tests. Incrustation, Economisers, Superheaters, Explosive Energy, Specification and Proportions of Lancashire and Vertical Boilers, &c.

INJECTORS.—Types, Size, Steam Supply, Delivery, Water Supply, &c., &c.

STEAM ENGINES.—Types, Cylinder Proportions and Ratios, Horse Power, Mechanical Efficiency, Friction, Water Consumption, Condensation, Types of Condensers, Reservoir Capacity, Crank Shafts, Governors, Bearings, Steam Pipes, Indicators and Diagrams, Tables of Laps, Cut-offs, Crank Angles, Hyperbolic Logs, Piston Constants, Pressures on Bearings, &c., &c.

GAS ENGINES.—Types, Arrangement of Otto Cycle, Circulating Tanks, &c., Proportions Air to Gas, Dowson Gas, Effects of Products of Combustion, Hints on Management, Results of Trials, &c.

OIL ENGINES.—Types, Flashing Point of Oils, Cycles, Cost of Working, Portable Oil Engines, &c.

TRANSMISSION OF POWER.—Shafting, Gearing, Belting, Rope Driving, with Tables of Powers, &c.

HYDRAULIC MACHINERY.—Accumulators, Intensifiers, Presses, Hydraulic Supply Installations, Water-wheels, Turbines, Pumps, &c., with numerous Tables.

ELECTRICAL ENGINEERING.—Units, Conductors, Electrical Pressure and Resistance, Arrangements of Circuits, Methods of Wiring, Jointing, and Insulating, Testing, Incandescent and Arc Lamps, Dynamos, Motors, Transformers, Switches, Accumulators, Electric Traction, Electric Welding, &c.

MINING ENGINEERING AND MACHINERY.—Fans, Friction of Air in Mines, Pumping Engines, Pulsometers, Conveyer Belts, Efficiency and Analysis of Coals, Power Transmission, Explosives, Pit Tubbing, Coal-cutting Machines, General Notes, &c., &c.

NOTES ON HEAT.—Thermometers, Temperature Test, Melting and Boiling Points of Metals, Alloys, Liquids, &c., Expansion of Metals and Fluids, Fuels, Combustion, Composition of Coals, &c., &c.

CUTTING TOOLS.—Angles, Speed of Saws, Wheels, Cutters, Grindstones, &c.; Proportions and Speeds of Milling Cutters.

FRICITION.—Solids and Fluids, Coefficients, Bearings and Alloys, Ball Bearings, &c.

TABLES.—Proportions and Weights of Pipes, Bolts, Nuts, Wires, Balls, Girders, &c.; Specific Gravities, Strength of Metals and Alloys, Timber, &c.; Circumferences, Areas, Squares, Cubes, &c.

NOTES ON PATENT LAW.—Provisional Protection, Complete Specification, Foreign Patents.

PRICE 1s. 6d. NET, POST FREE 1s. 8d.,
OR FREE TO ANNUAL SUBSCRIBERS TO THE JOURNAL.
FOREIGN REMITTANCES BY INTERNATIONAL MONEY ORDER.

THE TECHNICAL PUBLISHING CO. LTD.,
31, WHITWORTH STREET, MANCHESTER, England.

SECOND EDITION.

Crown 8vo, cloth, price 4s. 6d. net.

THE INDICATOR AND ITS DIAGRAMS: WITH CHAPTERS ON ENGINE AND BOILER TESTING

By CHARLES DAY, Wh.Sc. Including a Table of Piston Constants,
compiled by W. H. FOWLER, Wh.Sc., M.I.Mech.E., Assoc.M.Inst.C.E.

This book is of a thoroughly practical character, and will be found of special value to engineers and inspectors. It contains numerous diagrams from actual practice.

EXTRACTS FROM THE PRESS.

"In no other publication is the information so fully and clearly elucidated. The book can be highly commended, as it is altogether the best book on the Indicator and on Engine and Boiler Testing that has thus far been published."—*American Engineer and Railroad Journal*.

"A really excellent book, which we have pleasure in recommending."—*Electricity*.

"The book is one of the most useful we have met with."—*Mechanical World*.

"We know of no other book which gives so much information."—*Science and Art of Mining*.

"The book is notable for its lucid explanations. There is scarcely a point left untouched."—*Textile Recorder*.

"The book is just what is wanted."—*Electrical Review*.

Crown 8vo, cloth, price 3s. 6d. net.

PROBLEMS IN MACHINE DESIGN. For the Use

of Students, Draughtsmen, and others. By CHAS. H. INNES,
M.A., Lecturer on Engineering at the Rutherford College, Newcastle-on-Tyne.

EXTRACTS FROM THE PRESS.

"This is an excellent work for Students in Engine and Machine Design. It contains many practical problems not generally found in other text-books. Designers will find it a most valuable book."—*American Machinist*.

"This little book is particularly useful."—*Power*.

"Of much value to draughtsmen and engineers, to whom we cordially recommend it."—*Mechanical World*.

"One of the few text-books conceived nowadays in the interest of the student."—*Iron and Coal Trades Review*.

"That the book will be valuable to many there can be no doubt, and it is to be cordially commended to the notice of engineering students."—*Steamship*.

Foreign Remittances by International Money Order.

THE TECHNICAL PUBLISHING CO. LIMITED,

31, WHITWORTH STREET, MANCHESTER, England.

**THE APPLICATION OF GRAPHIC METHODS
TO THE DESIGN OF STRUCTURES.** Specially prepared for the use of Engineers. Profusely illustrated. A Treatment by Graphic Methods of the Forces and Principles necessary for consideration in the Design of Engineering Structures, Roofs, Bridges, Trusses, Framed Structures, Walls, Dams, Chimneys, and Masonry Structures. By W. W. F. PULLEN, Wh.Sc., Assoc.M.Inst.C.E., M.I.Mech.E. Price 6s. net.

EXTRACTS FROM THE PRESS.

"The book will doubtless prove of considerable service, not only to those for whom it is mainly intended, but for students in mechanics and machine design."—*Mechanical World*.

"Engineers generally will find this work of much value."—*Steamship*.

"In this book much ground is covered and cases dealt with which are not usually met with in similar works on the subject."—*The Builder*.

"The volume is a welcome addition to the practical series of books published by this firm."—*Electricity*.

**CENTRIFUGAL PUMPS, TURBINES, & WATER
MOTORS:** including the Theory and Practice of Hydraulics (specially adapted for engineers). By CHAS. H. INNES, M.A., Lecturer on Engineering at Rutherford College, Newcastle-on-Tyne. Price 3s. 6d. net.

EXTRACTS FROM THE PRESS.

"Those who have wanted a simple treatment of the theory and design of Centrifugal Pumps and Turbines will welcome this book, and we can recommend it."—*The Engineer*.

"No efforts have been spared to make the text clear."—*Engineer and Iron Trades Advertiser*.

"The student, the draughtsman, and engineer will all find matter of interest."—*Indian Textile Journal*.

"The book will be found of special value to engineering students preparing for the honours stages of the Science and Art and Technological Examinations in Machine Construction and Mechanical Engineering."—*Steamship*.

Foreign Remittances by International Money Order.

THE TECHNICAL PUBLISHING CO. LIMITED,
31, WHITWORTH STREET, MANCHESTER, ENGLAND.

ENGINEERING ESTIMATES AND COST ACCOUNTS. By F. G. BURTON, formerly Secretary and General Manager of the Milford Haven Shipbuilding and Engineering Co. Limited. Price 3s. net.

EXTRACTS FROM THE PRESS.

"The book is one in a field little occupied, and is one that may be commended." *The Engineer.*

"As a useful and concise handbook on the subject, the book deserves to be cordially commended."—*Mechanical World.*

"To all who have to do with engineering estimates and cost accounts this treatise should prove eminently useful. It is to be heartily commended to the notice of managers, foremen, and draughtsmen."—*Steamship.*

"This book is a useful addition to the literature of a subject which receives much less attention than it ought."—*Textile Recorder.*

INJECTORS: THEORY, CONSTRUCTION, AND WORKING. By W. W. F. PULLEN, Wh.Sc., Assoc.M.Inst.C.E., M.Inst.M.E. Price 3s. 6d. net.

EXTRACTS FROM THE PRESS.

"The book is one of the best that has yet come under our notice."—*Safety Valve.*

"The book is unexceptionable in every way."—*Indian Engineer.*

"We commend it as a useful handbook on this interesting subject."—*Mechanical World.*

"This is a capital little work, which may be recommended to all who wish to learn about injectors and ejectors. . . . It is, we think, the best work on injectors published."—*English Mechanic.*

OPENING BRIDGES. By GEORGE WILSON, M.Sc., Demonstrator and Assistant Lecturer at the University College of South Wales, Cardiff. Price 2s. net.

EXTRACTS FROM THE PRESS.

"Contains much of interest and value on a subject which has received too little attention in works on bridge building."—*American Machinery.*

"It is some time since we read such a succinct and interesting little work."—*Railway Engineer.*

"No book, so far as we know, presents so clearly and practically all the information we need to know on this subject."—*Science and Art of Mining.*

Foreign Remittances by International Money Order.

THE TECHNICAL PUBLISHING CO. LIMITED,
81, WHITWORTH STREET, MANCHESTER, ENGLAND.

THE NAVAL ENGINEER AND THE COMMAND OF THE SEA. A Story of Naval Administration. By FRANCIS G. BURTON. Price 2s. 6d. net.

THE ABC of the DIFFERENTIAL CALCULUS. By W. D. WANSBROUGH, author of "Portable Engines," "Proportions and Movement of Slide Valves," &c. Price 3s. net.

PRACTICAL NOTES ON THE CONSTRUCTION OF CRANES AND LIFTING MACHINERY. By EDWARD C. R. MARKS, Assoc.M.Inst.C.E., M.I.Mech.I. Price 2s. 6d. net.

MARINE ENGINEERS: THEIR QUALIFICATIONS AND DUTIES. With Notes on the Care and Management of Marine Engines, Boilers, Machinery, &c. By E. G. CONSTANTINE, M.I.Mech.E. Price 5s. net.

HEAT AND HEAT ENGINES. A Treatise on Thermodynamics as Practically Applied to Heat Motors. Specially written for Engineers. By W. C. POPPLEWELL, M.Sc. Price 6s. net.

MECHANICAL ENGINEERING MATERIALS. By EDWARD C. R. MARKS, Assoc.M.Inst.C.E., M.I.Mech.E. Price 1s. 6d. net.

Foreign Remittances by International Money Order.

THE TECHNICAL PUBLISHING CO. LIMITED,
31, WHITWORTH STREET, MANCHESTER, ENGLAND.